



International Federation of Roller Sports

**ROLLER INLINE HOCKEY
RULES OF THE GAME
AND
ORGANIZATIONAL RULES**

2005 Edition

COMITE
INTERNATIONAL
DE



**ROLLER
IN-LINE HOCKEY**

The Official Publication of the
International Committee of Roller Inline Hockey
A Discipline of the
International Federation of Roller Sports
2005

PART I –	Governing Authority	Page 3
PART II -	General Game Regulations	Pages 3-6
PART III –	Rules of the Game	Pages 6-31
	 Inline Rink Diagram	Page 7
	 Official Goal Cage Specification	Page 9
	 Penalty Index	Pages 29-31
PART IV –	CIRILH Organizational Rules	Pages 32-36
PART V -	CIRILH General Rules	Pages 37-41
PART VI -	CIRILH World Championships	Pages 41-47
PART VII –	International Inline Hockey Referees . .	Pages 47-51
PART VIII –	Applicable FIRS Statutes & Bylaws. . .	Pages 52-58
PART IX –	FIRS Medical Regulations	Pages 58-60
PART X –	Past World Inline Hockey Champions .	Pages 61-62

FIRS
International Committee of Inline Roller Hockey
George Pickard – President
3020 Prescott Avenue
Lincoln, Nebraska 68502
USA

E-mail: pickard.cirilh@alltel.net
Phone: 1-402-489-1550

**The English language version of CIRILH and
FIRS Regulations are the official document
for World Inline Hockey Championship Rules**

INDEX FOR CIRILH RULES OF THE GAME

Face Off – Rule 48
Falling On Puck – Rule 49
Fighting – Rule 50
Forfeiture of Games – Gen. Reg. 5 & Rule 67
Game Duration – Gen Reg. 4 & Rule 72
Goal Cage and Crease Specifications – Rule 2
Goals & Assists – Rule 51
Government of Sport – Part I
High Stick Definition – Rule 54
Kicking Puck – Rule 60
Medal Round Game Selection – Gen Reg. 10
Official's Duties – Rules 32 – 37
Penalty Bench – Rule 6 & 61
Penalty Classification & Times – Penalty Index follows Rule 75
Penalty Definitions – Rules 23 – 27
Penalty Delayed – Rule 30
Penalty for Goal Keeper – Rule 29
Penalty Shot – Rule 28
Players Bench – Rule 5 & 61
Player Equipment – Rules 15-19
Pool Play – Gen Reg. 7
Protests – Gen Reg. 13
Puck Not Playable – Rule 64 & 66
Refusal to Play, Forfeiture – Rule 67
Rink Specifications – Gen Reg. 3 & Rule 1
Seeding Teams – Gen Reg. 8
Shoot Outs (Ties) – Rule 73(c)
Single Elimination – Gen Reg. 10
Sudden Death Play – Rule 73
Team Eligibility – Gen Reg. 1
Team Composition – Gen Reg. 2 & Rules 9 & 11
Tie Breaking Rules – Gen Reg. 9
Tied Games – Rule 73
Time Outs – Rule 72
Uniforms – Rule 21
World Championship Game Structure – Gen Reg. 6

FIRS INTERNATIONAL ROLLER IN-LINE HOCKEY CHAMPIONSHIPS

PART I - GOVERNING AUTHORITY

Rules and regulations for conducting international Roller In-Line Hockey Championships have been established through the Committee International de Roller In-Line Hockey (CIRILH), an organization and discipline of the International Federation of Roller Sports (FIRS).

All FIRS recognized National Federations in good standing are hereby granted permission, without charge, to reproduce and distribute these rules in their own national languages as a means to promote FIRS inline roller hockey programs throughout the world. However, it must be understood that any subsequent differences or inconsistencies resulting from translation must defer for final disposition to this original English version that is the Official FIRS statements as to the Organizational and Playing Rules for the sport of international roller inline hockey.

The CIRILH Committee shall have full governing control over the Roller In-Line Hockey World Championships, which must be played in accordance with these rules, as well as all Statutes and Administrative Rules of FIRS.

PART II - GENERAL GAME REGULATIONS

1. Eligibility of Teams and Players

A. The World Inline Roller Hockey Championships are open to the National Teams of all the National Federations affiliated with the FIRS, provided that they confirm their entry prior to the closing date for entries laid down by the CIRILH and forward payment of appropriate entry fees. (See Part III, Article 1 of Org. Rules)

B. Players should normally be of the same nationality as the team for which they are playing and have a valid passport from the country represented.

C. All players must wear in-line roller skates (see Rule Sixteen), and the game will be played with a puck (See Rule Twenty). For required player protective equipment, consult Rule Eighteen

D. Junior Teams: The official CIRILH Junior Championship age level for International competitions for both male and female players is age fourteen (14) through eighteen (18) as calculated on January 1 of the year of the championship.

E. Senior Teams: The minimum age is fourteen (14) years as calculated on January 1 of the year of the championship. This applies to both men and women teams. There is no maximum age limitation.

2. Team Size

A. At no time shall any team have more than five players on the floor during a game. To officially start the game a team must have four (4) skaters and a goalie on the floor ready to play. (See Rule Nine)

B. Team rosters will consist of a minimum of six (6) floor players and two (2) goalies and a maximum of 14 floor players and 2 goalies. Once the championship has begun, no roster substitutions or the addition of players is permitted.

3. Rink Condition

A. The World Championship will be played on a surface as close as possible to the maximum size allowed of 30 X 60 meters. The surface shall have rounded corners to facilitate keeping the puck in play.

B. Roller in-line hockey shall be played on an appropriate surface, with markings as approved by the CIRILH.

C. There are no blue line markings required on the playing surface for roller inline hockey, where the entire floor is in play for either team, without imposition of off-side or icing penalties. (See Rule One). However, a center red line should be marked on the floor to distinguish the defensive zone and the attacking zone. (See Rules Seventy-One and Seventy-Four)

4. Duration of Games

A. Regulation World Championship games will be played in two periods of twenty (20) minutes each, with a five (5) minute rest at half time.

B. Each team is granted one time out of one-minute duration per period.

C. If a tie exists at the end of single elimination competition, the outcome of the game shall be settled in periods of sudden death overtime, consisting of ten (10) minutes each, with three minute rest periods, until the winner of the game is settled. (See Rule Seventy-Three (b) – Tied Games). Overtime periods do not apply to games tied in round-robin

matches.

5. Forfeiture

A forfeiture of a game shall be declared for the following reasons:

- A. If a team when ordered to do so by the Referee, through its manager or coach, fails to go on the floor and commence play within five minutes, the game shall be forfeited.
- B. At the start of a game (referee's whistle to put puck in play) a team does not have four floor players and a goalie on the floor, in full and required uniform.
- C. Due to injury or illness during the game a team cannot field (when at full strength) four players and a goalie to continue this game.
- D. A team may forfeit one game during the round-robin portion of the tournament without disqualification of that team for the entire tournament. If the same team forfeits a second game at a tournament, that team shall be disqualified for the remainder of all tournament games. Any single forfeiture occurring after completion of round-robin games, involving either the medal play or the placement games, will also cause a team to be disqualified for the remainder of the tournament.
- E. In the event of a forfeit then the following scoring statistics shall be awarded:
 - i. The score of the game shall be recorded as 1 to 0, with the forfeiting team awarded a loss for the game and the opposing team shall be awarded two points (a victory for the game).
 - ii. The forfeiting team (loser), while still admitted to round-robin play, is penalized a minus 2 points (-2) for that game, which must be deducted from their accumulated points total for the round robin. (See Rule Sixty-Seven)

6. Structure of World Championship Games

- A. All World Championships for roller inline hockey shall begin with pool play (round-robin) in which all participating teams shall qualify for order and selection to participate in the Championship medal games. Pool play may consist of one or more groups in which every team assigned to the group plays all other teams in that group. A predetermined number of teams finishing highest in the group will go on to play in the Championship medal games and the non-qualifying teams will compete for the final places remaining.
- B. The Championship medal games shall be conducted as single elimination matches, with winners advancing and the losing teams playing placement games to determine their final championship positioning. No ties are permitted in medal competitions and shall be determined by sudden death (first team to score wins) overtime periods. (See Rule 73 (b))

7. Round-robin Pool Play

The number of groups into which World Championship participating teams are divided for round-robin pool play shall be according to the chart below:

# Teams	Pools/Teams Per	Teams to Finals	# Pool Games	Finals Games	Playback Games	Total Games
8	1 pool of 8	All 8	28	8	4	40
9	1 pool of 9	Top 8	36	8	7	51
10	2 pools of 5	Top 8	20	8	4	32
11	2 pools of 5 –6	Top 8	25	8	5	38
12	2 pools of 6	8 = Top 4/each pool	30	8	9	47
13	2 pools, 6 - 7	8 = Top 4/each pool	36	8	13	57
14	2 pools of 7	8 = Top 4/each pool	42	8	13	63
15	2 pools 7 - 8	8 = Top 4/each pool	49	8	13	70
16	2 pools of 8	8 = Top 4/each pool	56	8	8	72
17	3 pools, 6-6-5	12 = Top 4/each pool	40	12	18	70
18	3 pools of 6	12 = Top 4/each pool	45	12	18	75
19	3 pools, 6-6-7	12 = Top 4/each pool	51	12	19	82
20	4 pools of 5	12 = Top 3/each pool	40	12	20	72
21	4 pools, 6-5-5-5	12 = Top 3/each pool	45	12	20	77
22	4 pools, 6-6-5-5	12 = Top 3/each pool	50	12	20	82
23	4 pools, 6-6-6-5	12 = Top 3/each pool	55	12	20	87
24	4 pools of 6	12 = Top 3/each pool	60	12	20	92

8. Seeding of Teams

- A. When the total team entry shall make it necessary to use a modified "round robin", teams will be seeded into two or more groups so that each group has "equal" strength which is based on their final placement at the previous year's World Championships. The teams will be assigned to groups arranged according to serpentine positioning as shown below. When a team from the previous year's World Championship does not participate, their position is closed up and the serpentine continues with those teams that have competed in both championships.
- B. The National Teams that did not compete in the previous World Championships will be arranged in alphabetical order according to the English spelling of the country's name and added to the serpentine, which continues until all teams are assigned to a group. For example, assume that 18 teams are competing. The teams would be grouped as shown after seeding has been determined:

Group 1	Group 2	Group 3
1st	2nd	3rd
6th	5th	4th
7th	8th	9th
A	11th	10th
B	C	D
G	F	E

9. Round-Robin Game Scoring and Tie Breakers

- A. In compiling the results of pool play, games within the pool that finish tied, shall remain tied and points for each game awarded as follows:

Two (2) points to the game winner
 One (1) point for a tie game
 Zero (0) points to the loser
 Minus (-2) points for a forfeit

- B. The placement of teams within each pool shall be according to the **most number of points accumulated** in round-robin play. If after addition of points, two or more teams are determined to possess an equal amount of points during pool play, the team's position is determined as follows:
- C. The **vector of the head-to-head competition** in the round-robin shall be awarded the higher placement position.
- D. If a tie still results, the team with the **lowest total number of goals-allowed** for the entire play-off round shall be used to determine position for the tied teams.
- E. If a tie remains, the **lowest total of goals-allowed in common wins among the tied teams**, during all games in the group competition, will determine the group positions.
- F. If a tie still results, the **highest total of goals scored in common losses** among the tied teams will determine their positions.
- G. If teams are tied after applying the above criteria, **a shoot-out will take place** as defined in Rule 73(c).

10. Medal Round Competition

- A. **Single Elimination:** The pre-quarter finals (if required), quarter finals, semi finals and final games of medal round competition will be conducted as single elimination matches. If a team loses a game in the pre-quarter finals or quarter finals, they are eliminated from any further advancement in Medal Play. Ties are to be decided by sudden death overtime according to provisions of Rule 73b. The two semi finals losing teams will play for the Bronze Medal; and the semi-final winners play for the Gold Medal, with the loser of this match receiving the Silver Medal.
- B. **Direct to Quarter Finals from One or Two Pools:** When championship play consists of 16 or fewer teams, the top eight teams will be placed in the quarter finals bracket according to the seeding determined by round-robin play. With single pool round-robin play, the first place finisher plays the last qualifying place, and so on through the remaining qualifiers. When round-robin play consists of two pools, the top seed in pool A will play the bottom qualifying seed in pool B, and so on, matching first place in one pool with last place in the other.
- C. **Structure of Pre-Quarter Finals from Three Pools:** When championship round-robin play consists of 3 pools, 12 teams qualify and pre-quarter finals are required. The winning team from each of the 3 pools will receive a bye into the quarter-finals. The 4th bye will be awarded to that team placing 2nd in its pool with: a) The best percentage of points earned divided by maximum points possible. If a tie exists between pools, b) The second place team with the lowest average of goals-allowed per game in round-robin play shall draw the bye. c) Should a tie still remain, a shoot out will be held among all remaining 2nd place round-robin teams that are tied for receipt of this bye. The remaining 8 qualifying teams will be seeded according to their respective placements into the pre-quarter final round, with the winners of each match advancing to face one of the 4 teams receiving the byes. Where possible, rematches of round-robin pool opponents will be avoided in pre-quarter final and quarter final matches.
- D. **Structure of Pre-Quarter Finals from Four Pools:** When championship round-robin play consists of 4 pools, pre-quarter finals are required. The 3 highest placements in each of the 4 pools will advance to medal play. The winning team from each of the 4 pools will receive a bye into the quarter-finals. The remaining 8 qualifying teams will be seeded into the pre-quarter final round, with the winners of each match advancing to face one of the 4

teams receiving the byes.

11. Placement Games for World Championships

Those teams not advancing to compete in medal competition from the preliminary pool play will play additional matches to determine their overall Championship positions. These games will take place in increments of 2, 3 or 4 team units based upon their equivalent round-robin group rankings. The placement games will determine their ultimate position within their selected group strata. Where there were two groups in the round robin, a four team match is possible which pits the higher placement team against the next lower placement team from the other group. The losers of these four team match-ups play for the lower of the open placements and the winners for the two higher positions. In a three team match, each team will play the other in a mini-round robin to fill these open positions. This procedure of layered competition will be repeated until all teams from the round-robin that are no longer competing for championship medals have been placed

12. Game Officials

- A. There will be two referees used in each game at the World Championship. They will share responsibilities; however, the first one listed on the game sheet will be designated Chief Referee to be final authority on violations that may involve controversy among officials. Other required officials include a time keeper, scorekeeper and a penalty box attendant that will be responsible for notifying the players of the expiration of their penalty time.
- B. CHIEF REFEREE - A certified CIRILH "A" International Referee, who shall be in complete charge of the game, players, all other officials, spectators and venue, responsible only to the jurisdictional authority of the CIRILH Committee. The Chief Referee's game decisions shall be final.
- C. REFEREE - A certified CIRILH International Referee appointed to assist the Chief Referee.
- D. GOAL JUDGE - Shall indicate when a goal is scored and carry out any other duties as assigned by the Chief Referee. This official is optional and such use during medal round matches shall be determined by the CIRILH.

13. Protests

- A. A protest made to the referee will not be valid unless made on the rink by the captain of the protesting team, and the referee will immediately inform the captain of the opposing team. Once the referee in charge of the match has ruled on an incident occurring during the course of play, this decision will stand unless an official letter of protest seeking to overturn this ruling is filed with the President of the CIRILH, along with a protest fee of \$US100 (or the equivalent in some other currency). The CIRILH will then investigate the protest. If it is upheld, the fee will be returned in full to the complainant. However, should the CIRILH determine the protest to be unjustified, the complainant will forfeit the fee.
- B. In the case of administrative protests (bad condition of the rink, player's equipment, unqualified players, etc.), only those made to the referee BEFORE the start of a match are valid. The referee will then advise the captains of both teams that the match is being played under protest. All protests must be confirmed by official letter addressed to the CIRILH President, accompanied by the necessary fee, within one and a half (1-1/2) hours of the end of the game. When sufficient time exists prior to the start of a game for settlement of such administrative protests, these will then become under the immediate jurisdiction of the CIRILH.
- C. Each participating federation has the right to lodge protests against any incidents (arbitrary or otherwise) which may arise during the course of the Championships. For a protest to be valid, it must be written and presented to the President of the CIRILH or his legal representative, not later than three (3) hours after the incident.
- D. All appeals (described in A. above) of the referee's decision must be filed in writing and submitted no later than three hours after the incident to a member of the CIRILH Executive Committee, along with an appeal fee of \$US100. See Article 24 of the Organizational General Rules.

PART III - RULES OF THE GAME

SECTION I

RULE ONE - RINK

- (a) Roller in-line hockey shall be played on wood, asphalt, cement or sport tiled floors or any appropriate surface approved by the CIRILH.
- (b) The rink shall be marked according to the diagram included with these rules taking into consideration the exact dimensions indicated herein. No playing surface blue line zone markings are needed, because in roller inline hockey the entire floor is in play for either team, without threat of face-offs for off-side incursions. However, a center red line should be marked on the floor to distinguish the defensive zone and the attacking zone.

Diagram of Roller In-Line Hockey Playing Area

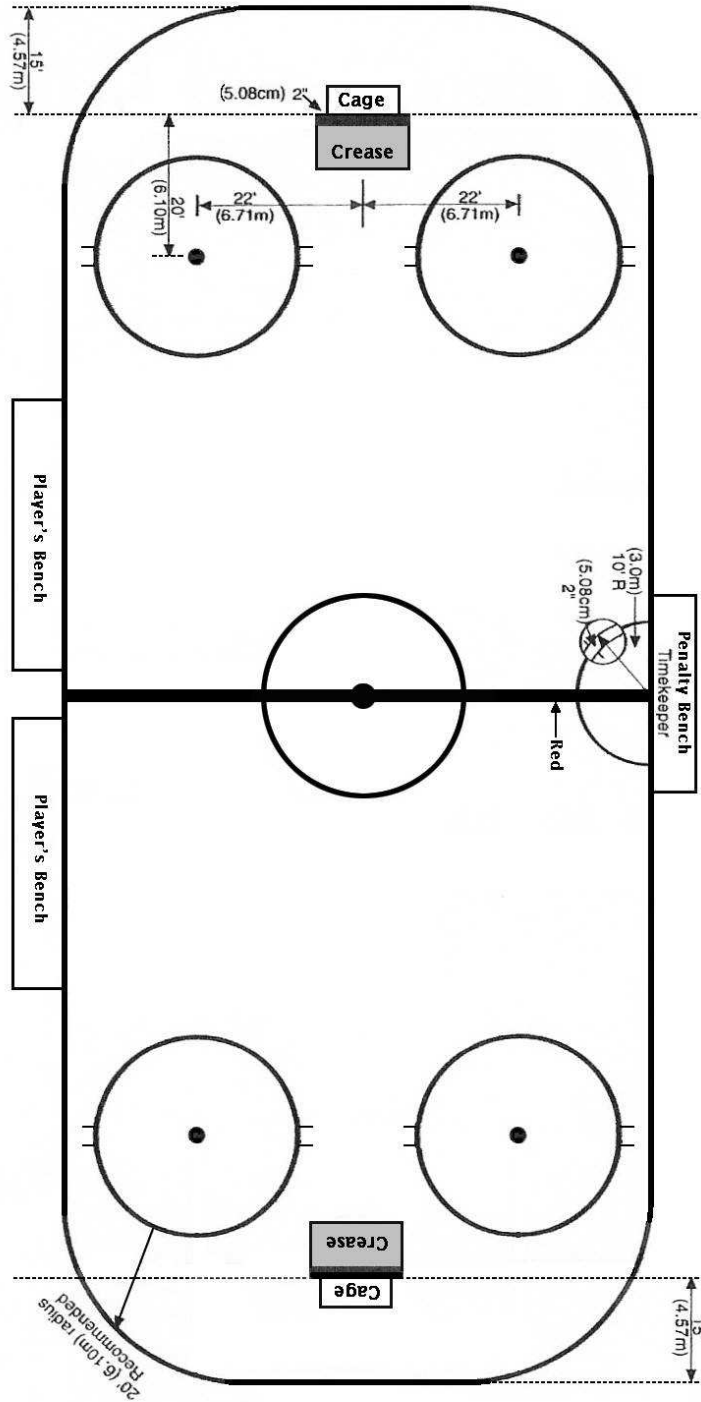

- (c) Dimensions of the rink surface may vary between 20 and 30 meters in width (65 to 100 feet) and 40 and 60 meters in length (130 to 200 feet). As much as possible, an attempt should be made to maintain a width versus length of rink ratio of 1:2
- (d) The World Championship will be played on a surface as close as possible to the maximum allowed. The rink shall be surrounded by a wood or fiberglass wall (boards) that extend above the rink surface from 40 to 48 inches (101 to 122 cm), with the ideal height being 42 inches or 106.7 cm. The barrier shall have rounded corners of a radius of approximately 20 feet (6 meters) to facilitate keeping the puck in play.
- (e) It is recognized that rinks of the size used at World Championships may not be available for all games within the jurisdiction of a National Federation, therefore, in such instances, variations in the marking of goal lines and face-off circles are authorized, which should be proportionate to the overall size of the playing surface. If such a rink will be used as venue for an international competition, in fairness to the participants, its dimensions must be included with the information sent out to invited national federations.

RULE TWO - GOAL CAGES

- (a) The goal cage consists of an iron pipe cage with a rectangular face opening with inside dimension height of 105 cm (41") and inside width of 170 cm (67") as shown in the inset diagram.
- (b) The front or facing frame must be made with iron galvanized pipe of 3-inch or 7.6 cm diameter. The top and base supports and the back brace shall consist of iron pipe 2-inches or 5 cm diameter. The bottom or supporting base of the goal cage shall extend in depth to 43 inches or 109 cm outside dimensions from the face of cage to the center of the back arc. The top supporting frame shall be 29 inches or 74 cm in outside depth dimensions. A two inch (5 cm) supporting brace at the back center of the cage shall connect the top and bottom frames. The top, posts and internal face of the goal cage must be covered with very resistant netting, which has yarn dense enough to resist the strongest shots, and closely woven so as not to permit through passage of the puck. Metallic netting will not be allowed.
- (c) A drop net must be suspended from the near inside top of the cage with a depth of 45 cms measured from the top cross bar of the goal. This cotton netting, thinner than the outside (external) one, has a maximum width of 180 cms and height of 110 cms, must be suspended inside the cage to prevent the puck rebounding from the inside of the goal. This net must be white in color and should be attached at the top only, allowing it to hang freely to the ground parallel to the posts of the cage. The posts and front bar must be painted in a fluorescent red or orange color while all other framing parts should be painted in white. It is required that the bottom rail of the goal cage and the back center brace be padded to resist having the puck bounce back out of the cage after a hard shot. If regular FIRS ball hockey goal cages are being used, the "kick" ramp across the bottom of the cage must be removed.
- (d) The goal cages are placed opposite at each end of the rink with the openings facing each other. The distance from the goal line to the extreme end of the rink is 15 feet or 4.5 meters.

RULE THREE - GOAL CREASE

- (a) In front of each goal, a "Goal Crease" area shall be marked by a red line 7.6 cm (3inches) wide. (See Rule 51 (a)).
- (b) This line shall extend at a right angle from a point on the goal line, 30 cm (1 foot) from the outside of each goal post for a distance of 1.2m (4 feet). A line parallel to the goal line shall join the ends of these two lines. It shall be understood that the area covered by the goal crease on the floor shall extend to all the space above the crease.

RULE FOUR - FACE-OFF SPOTS

- (a) One face-off spot, nine inches in diameter (22.5 cm) shall be placed at the exact center of the floor, surrounded by a 15 feet radius circle (4.6 meters). (The game will be started with a Face-Off from this spot, as will the beginning of the second half of the game, after each scored goal and before sudden death play-offs.)
- (b) In each end zone, two 9 inch face off spots will be placed, located 20 feet (6 meters) out from each goal line and 22 feet (6.7 meters) from the exact center of the rink's width, along an imaginary line parallel to the goal line. This would make the spots 44 feet (13.4 meters) apart from each other. A fifteen feet (4.6 meters) radius circle shall be drawn around each spot.
- (c) The rink will be marked with a total of five (5) face-off positions.

RULE FIVE - PLAYER BENCHES

- (a) Each rink should have seats or a bench for the use of each team, to be known as the "Player Benches." Each player bench shall accommodate at least sixteen (16) persons and shall be placed immediately alongside the playing surface as near as possible to the center of the rink and convenient to the dressing rooms.
- (b) The two teams will start at the opposite end zone of their respective player's bench and will not change benches at the end of every period.
- (c) Only players in uniform, the manager, coach and trainers shall be permitted to occupy the player benches.
- (d) During the game, coaches, managers and trainers shall be restricted to the use of the area the length of the player benches, including their team gate. Penalty for violation of this rule is a Bench Minor Penalty.

RULE SIX - PENALTY BENCH

Each rink will have seats or benches to be known as the "Penalty Bench." It is to be used for the seating of penalized players, Penalty Time-keeper, Game Time-keeper and Official Scorer. The penalty bench should be located a substantial

distance from the player benches.

OFFICIAL FIRS GOAL CAGE

REQUIRED FOR CONTINENTAL AND WORLD CHAMPIONSHIPS



All framework is to be constructed of galvanized iron pipe conforming to the specified diameters and dimensions of these diagrams.

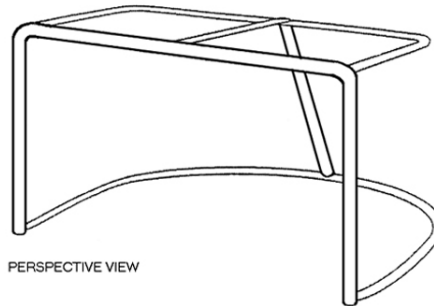

PERSPECTIVE VIEW

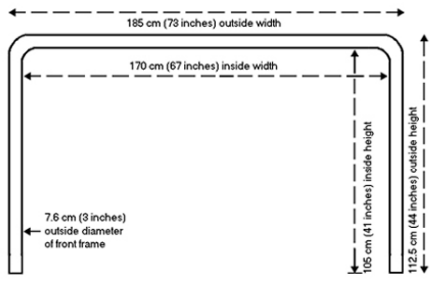

FRONT FRAME

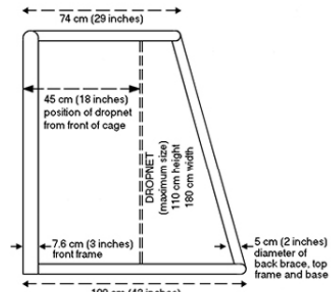

SIDE VIEW

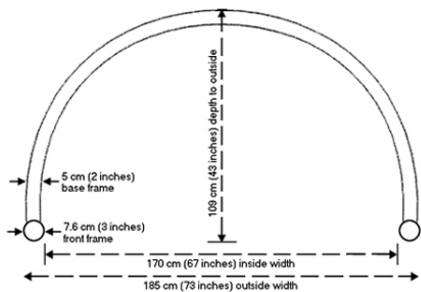

BASE STRUCTURE

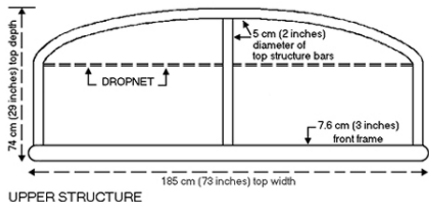

UPPER STRUCTURE

RULE SEVEN - REFEREE'S CREASE

A line in the shape of a semi-circle and with a 10 feet (3m) radius shall be marked on the floor immediately in front of the Penalty Time-keeper's bench. Players are restricted from entering this area during stoppage of play without permission from the referee.

RULE EIGHT - SIGNAL AND TIMING DEVICE

Each rink must have a suitable sound device to be used by the Game Time-keeper. An electric timing device shall be provided for the purpose of keeping participants informed as to the various timed elements of the game. The timing display shall indicate the time remaining to be played and penalty time to be served.

SECTION II - TEAMS

RULE NINE - COMPOSITION OF TEAM

- (a) A team on the floor shall not consist of more than four floor players and one goalie.
- (b) Each player and each goalkeeper listed in the line-up of each team shall wear an individual identifying number at least 20 to 25 cm (8 to 10 inches) high on the back of the jersey.
- (c) Team rosters will consist of a minimum of six (6) floor players and two (2) goalies and a maximum of 14 floor players and 2 goalies. Once the championship has begun, no roster substitutions or the addition of players is permitted.
- (d) In acknowledgement to the preceding minimum roster requirements, a game nevertheless shall not be forfeit or a team disqualified, unless the team falls below the size causing forfeiture as contained in Rules 12 (b) and 67 (c).

RULE TEN - TEAM CAPTAIN

- (a) One Captain shall be appointed by each team, and that player alone shall have the privilege of discussing with the Referee any question relating to interpretation of rules which may arise during the progress of a game. The Captain shall wear the letter "C," approximately 3 inches in height and in contrasting color, in a conspicuous position on the front of the jersey.
- (b) Each team should have a Captain on the floor at all times. If a Permanent Captain is not on the floor, Alternate Captains (not more than three) shall be accorded the privileges of the Captain. Alternate Captains shall wear the letter "A," approximately 3 inches in height and in a contrasting color, in a conspicuous place on the front of their jerseys.
- (c) The referee or official scorer shall be advised prior to the start of each game, the name of the Captain of the team, also the identity of the players who will serve as Alternate Captains when the Permanent Captain is off the floor.
- (d) No goalkeeper shall be entitled to exercise the privileges of Captain or Alternate Captain on the floor.
- (e) Only the Captain or Alternate Captain on the floor at the time of the stoppage of play (but not both) shall have the privilege of discussing with the Referee any point relating to the interpretation of rules. Any Captain, Alternate Captain or player who comes off the bench and makes any protest or intervention with the Referee for any purpose must be assessed a misconduct penalty.
- (f) The team captain and/or the team coach must sign all score sheets after each game, along with the game referees to verify the accuracy of the tally.
- (g) A complaint about a penalty is not a matter relating to the "Interpretation of the Rules" and a misconduct penalty shall be imposed against any Captain, Alternate Captain or other players making such a complaint.

RULE ELEVEN - UNIFORMED PLAYERS

- (a) At the beginning of each game the manager or coach of each team shall list the players and goalkeepers who shall be eligible to play in the game.
- (b) A list of the names and numbers of eligible players entered into that game must be handed to the Referee or Official Scorer before the start of the game. These players names must be contained on the original team roster submitted at the beginning of the World Championship. No change in the game list or additions thereto shall be permitted after the commencement of the game except when a goalkeeper has been injured or becomes ill. The name of another goalkeeper may be designated on the list in substitution for the injured or ill goalkeeper, however, such substitution can only be made by a player already on the list.
- (c) Each team shall be allowed one goalkeeper on the floor at one time. The goalkeeper may be removed and another "player" substituted. Such substitute shall not be permitted the privileges of the goalkeeper.
- (d) Any substitute goalkeeper entering the game for any reason shall not be permitted a warm-up.

RULE TWELVE - STARTING LINE-UP

- (a) Prior to the start of the game, the manager or coach of each team is required to name the starting line-up to the Referee or the Official Scorer.
- (b) To start a game a team must have a goalie and four skaters on the floor at the referee's whistle to start the game. If this requirement cannot be met then a forfeit shall be declared by the referee against the team not able to field a goalie and four skaters.

RULE THIRTEEN - CHANGE OF PLAYERS

- (a) When play is in progress, not more than five players (including a goaltender) are permitted on the playing surface at any one time.
- (b) Players may be substituted at any time from the player benches, provided that the player or players leaving the surface shall be within 3m (10') of their player's bench before any change is made.
- (c) Players on the penalty bench, who are to be substituted after the penalty has expired, must proceed by the way of the playing surface and be at their own player's bench before any substitution can be made.
- (d) A team shall be required to place the correct number of players on the surface when requested to do so by the referee. The visiting team must be first to place any playing line-up on the surface to commence play at all times. Each team is allowed only one change of players during a stoppage of the play.
- (e) If in the course of making a substitution, either the player entering the game or leaving the game intentionally plays the puck with their stick, skates or hands or makes physical contact with an opposing player while the player (either leaving or entering the game) is actually on the surface, then a Minor Penalty for "too many men on the surface" shall be assessed. However, in the course of leaving or entering the game, the player is accidentally struck by the puck, no penalty shall be assessed and play shall not be stopped.
- (f) When a goaltender leaves the goal area and proceeds to the player's bench for substitution, this must be done within 3m (10') of the bench area before the substitute may enter the game. If the team substituting has possession of the puck and the substitution is made prematurely, the official shall stop play immediately and a face-off will take place at either the center face-off spot or end zone face-off spot (whichever location gives advantage to the non-offending team). If the team does not have possession of the puck and makes an illegal substitution, the referee shall assess a Minor Penalty.
- (g) For player changes during stoppages of play, the referee conducting the face-off, will assume the referee's normal position for the ensuing face-off and then shall allow a five second interval for which the visiting team may make a change. After this five second interval has elapsed, the referee shall raise an arm to indicate that the visiting team may no longer change any players. With the arm still raised, the referee shall allow the home team the opportunity to make a change of players (if they have not already done so). After another five seconds time interval, the referee shall drop the arm. This will indicate that the home team may no longer change any player(s). When a team attempts to make a player change after the allotted time intervals, the referee shall send the player(s) back to their bench. Any subsequent infraction of this procedure shall result in a Bench Minor Penalty.
- (h) If in the last two minutes of regular playing time, a Bench Minor Penalty is imposed for DELIBERATE illegal substitution by the defending team, which provided them more men of the floor, a Penalty Shot shall be awarded to the non-offending team. The Bench Minor Penalty shall not be served.
- (i) A Bench Minor Penalty shall be assessed for violation of any section of Rule 13. The penalty shall be served by that player who committed the infraction.

RULE FOURTEEN - INJURED PLAYERS

- (a) When a player, other than a goalkeeper is injured or compelled to leave the floor during a game, the player may retire from the game and be replaced by a substitute, but play must continue without the teams leaving the floor.
- (b) If a goalkeeper sustains an injury or becomes ill, the goalie must be ready to resume play immediately or be replaced by a substitute goalkeeper and NO additional time shall be allowed by the Referee for the purpose of enabling the injured or ill goalkeeper to resume position. No warm-up shall be given to the replacement goaltender. (See also item (d) below.)
- (c) The Referee shall report to the CIRILH Committee, for possible disciplinary action, any delay in making a goalkeeper substitution. The substitute goalkeeper shall be subject to the regular rules governing goalkeepers and shall be entitled to the same privileges.
- (d) When a substitution for the regular goalkeeper has been made, such regular goalkeeper shall not return to the game until the first stoppage of play thereafter.
- (e) If an injured player receives a minor penalty the penalized team shall place a substitute player on the penalty bench before the penalty expires and no other replacement for the penalized player shall be permitted to enter the game except from the penalty bench. For violation of this rule a Bench Minor Penalty shall be imposed.
The penalized player who has been replaced on the penalty bench shall not be eligible to play until that penalty has expired.
- (f) When a player is injured so that the skater cannot continue play or go to the team bench, the play shall not be stopped until the injured player's team has secured possession of the puck. If the player's team is in possession of the puck at the time of injury, play shall be stopped immediately, unless the injured player's team is in a scoring position.
- (g) A player other than the goalkeeper whose injury appears serious enough to warrant a stoppage of play may not

participate further in the game until the completion of the ensuing face-off.

(NOTE) In a case where it is obvious that a player has sustained a serious injury the referee may stop the play immediately regardless of who is in possession of the puck.

SECTION III

RULE FIFTEEN - STICKS

- (a) The sticks shall be ice hockey-style made of wood or other approved material and must not have any projections. Adhesive tape of any color may be wrapped around the blade for the purpose of reinforcement or to improve control of the puck.
- (b) No stick shall exceed 1.5m (60") in length from the heel to the end of the shaft, nor be more than 32 cm (12.5") from the heel to the end of the blade. The curvature of the blade of the stick shall not be restricted. The blade of the floor players' stick must be a minimum of 5 cm and may not exceed 9 cm in width at any point.
- (c) The blade of the goalkeeper's stick may not exceed 13 cm in width at any point except at the heel where it must not exceed 14 cm in width; nor shall the goalkeeper's stick exceed 39 cm in length from the heel to the end of the blade. The widened portion of the goalkeeper's stick extending up the shaft of the blade shall not extend more than 61 cm from the heel and shall not exceed 13 cm in width.
- (d) A minor penalty shall be assessed any player, including the goalkeeper, for using a stick which does not conform to the provisions of this rule.

RULE SIXTEEN - SKATES

- (a) Skates to be used will be in-line skates only and may consist of either three or four wheels for floor players. Goalies may, as an option, use five wheel inline skates with smaller wheels, provided that all wheels are contained beneath the goalie boot and do not protrude either front or back. If skates are manufactured for a specific number of wheels, all wheels must be in place. All wheel bolts and axles must be recessed and even with the frame or covered with protective material so as not to injure other players or mar the skating surface. No quad or conventional skates will be permitted in World Championship play, although individual federations may allow the use of quad or conventional skates for domestic play.
- (b) Any player taking the surface in violation of the above rule will receive a minor penalty and may not return to play until the fault is corrected.

RULE SEVENTEEN - GOALKEEPER'S EQUIPMENT

- (a) With the exception of skates and sticks, all equipment worn by the goalkeeper must be constructed solely for the protection of the head or body, and must not include any garment or contrivance which would give the goalkeeper undue assistance in keeping goal.
NOTE: The lacing or webbing or other material joining the thumb and index finger of the goalkeeper's glove or any cage, pocket or pouch created by this material, must not exceed the minimum amount of material necessary to fill the gap between the thumb and the index finger when they are fully extended and spread.
 - 1) Protective padding attached to the back of, or forming part of, the goalkeeper's gloves shall not exceed 20 cm in width nor 40 cm in length.
 - 2) Abdominal aprons extending down the thighs or the outside of the pants are prohibited.
- (b) Goalkeeper's pads when new shall not exceed 30 cm in extreme width as measured on the goalkeeper, and shall not be altered in any way.
- (c) A minor penalty shall be assessed a goalkeeper guilty of using or wearing illegal equipment. (Refer to Rule 24)
- (d) All equipment, with the exception of puck and skates will be regulation hockey equipment.
- (e) All goalkeepers will be required to wear HECC/CSA approved face masks.

RULE EIGHTEEN - PROTECTIVE EQUIPMENT

- (a) All protective equipment except gloves, head gear or goalkeeper leg pad, must be entirely under the uniform. Leather elbow patches on the outside of the jersey are prohibited. After one warning by the Referee, a minor penalty shall be imposed on the offending player for violation of this rule.
- (b) All players must wear HECC/CSA-approved helmets, with a chin strap properly fastened. Full-face protection must be attached to the helmet for all Junior Team players and for everyone playing the Senior Championships that is under the age of eighteen (18) years. This regulation applies to both men and women players. Those players who are over the age of 18 have the option of using this protection, the absence of a face shield to be taken at their own risk.
- (c) It is compulsory for all goalkeepers to wear approved face masks.
- (d) All players must wear approved hockey gloves.
- (e) All players must wear shin guards and elbow pads. Male players must wear protective cup at all times during the game. Female players/goalkeepers must wear pelvic protective equipment at all times during the game.
- (f) A mouthpiece is optional, but recommended.
- (g) Eyeglass wearers must have plastic, not glass, lenses in their eyewear.
- (h) A minor penalty may be assessed for a violation of protective equipment.

RULE NINETEEN - DANGEROUS EQUIPMENT

- (a) The use of pads or protectors made of metal or any other material likely to cause injury to a player is prohibited.
NOTE: All elbow pads which do not have a soft protective covering of sponge rubber or a similar material at least 125mm (1/2") thick shall be considered dangerous equipment.
- (b) A glove from which all or part of the palm has been removed or cut to permit the use of bare fingers shall be considered illegal equipment and if any player wears such a glove in play a minor penalty shall be imposed on that player.
- (c) Any player wearing a protective device from a physician must have the permission of the CIRILH prior to playing.

RULE TWENTY - PUCK

- (a) The puck shall be the puck approved by the CIRILH Committee. The home team or host shall be responsible for providing an adequate supply of official pucks. This supply of pucks shall be kept at the penalty bench under the control of one of the regular minor officials or a special attendant.

RULE TWENTY-ONE - UNIFORMS

- (a) Uniforms will require identical long-sleeve shirts and full-length pants. Goalie jerseys will be the same color and design as other team members. Player numbers will be required only on the backs of the jerseys with whole numbers only from 00 to 99 and 20 -25 cm (8-10") in height.
- (b) The goalkeeper if male must at all times during the game wear a protective cup and pelvic protection if female, a chest protector which conforms to the body, regulation goalkeeper's gloves (ice hockey, non-modified, goalkeeper's pads not exceeding 30 cm in width, and a face mask or helmet with face guard attached). If the goalkeeper wears forearm guards they must be soft and pliable and conform to the player's forearms. Any regulation ice hockey equipment is acceptable.
- (c) All players participating in contests will be uniformed and have two jerseys of different colors. Full-length pants are required.
- (d) No two members of the same team will be assigned or permitted to wear the same number. Individual player's numbers may not be changed or substituted after the preliminary team registration without the written approval of the CIRILH Committee. One team Captain and three Alternate Captains shall have a small "C" or "A" on the right shoulder of their jersey.
- (e) It will be the responsibility of the home team to change its jerseys if the colors of the competing teams conflict. The decision in this matter shall be left to the Referee in charge of the game. The home team is to wear a predominately light colored jersey.
- (f) The entire team uniform: "jersey and pants" must match for each player in style and color.

RULE TWENTY-TWO - UNIFORM INSPECTION

- (a) The officials in charge of the game shall perform equipment inspection prior to the start of the game. No penalty shall be charged to a player before the start of the game for wearing equipment not in conformity with the rules. Wearing of illegal or dangerous equipment after the start of the game shall be corrected according to the rules.

SECTION IV**RULE TWENTY-THREE - PENALTIES**

- (a) Penalties shall be actual playing time and shall be divided into the following classes:
 - 1) Minor Penalties
 - 2) Bench Minor Penalties
 - 3) Major Penalties
 - 4) Misconduct Penalties
 - 5) Match Penalties
 - 6) Game Misconduct Penalties
 - 7) Penalty Shot

NOTE: In CIRILH In-line Roller Hockey Rules of the Game the skating surface is not divided into zones marked by blue lines. Therefore, no penalties or play interruptions exist in these rules pertaining to shots crossing multiple zones or players being "off-sides," other than the required team line-up on face-offs as denoted in Rule 48.

- (b) Coincidental Minor/Major Penalties are penalties that do not cause either team to be shorthanded (i.e. 4 on 4 or 3 on 3), and occurs when player(s) from both teams simultaneously receive equal length penalties. When coincident penalties are assessed, the penalized players take their places on their respective penalty benches, and both teams are able to make immediate substitutions for these penalized players. The penalized players are required to serve the full amount of assessed time and must remain in the penalty box until the first stoppage of play after the expiration of time. If one team is already short a player because of an earlier penalty, coincidental penalties will not change the number of players on the floor.
- (c) Players may not leave the penalty bench until their penalty has expired, half-time occurs or the end of the game. The player may not leave for any other reason. Any overtime period shall be considered part of the game and all unexpired penalties shall remain in force. All players in the penalty box must remain seated until the penalty time is

expired.

NOTE: When play is not actually in progress and an offense is committed by any player, the same penalty shall apply as though play were actually in progress.

- (d) When a penalized player's time has expired or been terminated by the scoring of a goal, that player must return to the surface prior to being substituted.

RULE TWENTY-FOUR - MINOR PENALTIES

- (a) For a "Minor Penalty," any player, other than a goalkeeper, shall be ruled off the floor to the penalty box for two minutes during which time no substitute shall be permitted. For an exception, see Coincident Penalty above. On the third (3rd) minor penalty in the same game to the same player, including the goal keeper, that player will receive an additional ten (10) minute misconduct penalty. NOTE: the player will have a substitute serve the minor penalty and the player will serve the entire penalty. Any subsequent penalty incurred within the game will result in that player being assigned a game misconduct.
- (b) A "Bench Minor" penalty involves the removal from the floor of one player of the team against which the penalty is awarded for a period of two minutes. Any player on the team may be designated to serve the penalty by the manager or coach through the playing Captain and such player shall take a place on the penalty bench promptly and serve the penalty as if it was a minor penalty imposed upon that player.
- (c) If while a team is "short-handed" by one or more minor or bench minor penalties the opposing team scores a goal, the first of such penalties shall automatically terminate. Penalties shall not reduce the on-surface strength of the teams below three on-surface players. Such penalties shall become delayed until such time as they can be served. NOTE: "Short-handed" means that the team must be below the numerical strength of its opponents on the floor at the time the goal is scored. The minor or bench minor penalty which terminates automatically when the team is scored against is the one which initially caused the team to be "short-handed" (first penalty). However, coincident minor penalties to both teams do NOT cause either side to be "short-handed," because although each team has a player in the penalty box, the number of floor players is not affected. Therefore, the penalty time awarded for coincidental penalties is never shortened by a goal being scored. This rule shall also apply when a goal is scored on a penalty shot, which was awarded in lieu of another penalty.
- (d) When a player receives a major penalty and a minor penalty at the same time, the major penalty shall be served first by the penalized player except under Rule 30 in which case the minor penalty will be recorded and served first. NOTE: This applies to the case where BOTH penalties are imposed on the SAME player. (See also note to Rule 30)
- (e) A coincidental penalty shall not deprive a team of its player advantage during the final minutes of the game when an opposing team has only two (2) floor players eligible for play (not including the goalie). Should such an opposing team provoke a coincidental penalty that cannot be fully served, because of insufficient time remaining in the game, the other team will retain its player advantage. Rule 30 states that a team shall not receive more than two simultaneous penalties, which would give the short-sided team incentive for provoking a concurrent penalty during the final minutes of play, with only the strong-sided team eligible to lose a player. A player on the short-sided team who creates such a penalty situation must leave the game, to be replaced by a teammate.

RULE TWENTY-FIVE - MAJOR PENALTIES

- (a) For the first "Major Penalty" in any one game, the offender, except the goalkeeper, shall be ruled off the floor to the penalty box for five minutes, during which time no substitutes shall be permitted. A goal scored does not terminate this penalty.
- (b) For the second major penalty in the same game, to the same player, including the goalkeeper, the player shall receive a five minute major penalty and an automatic game misconduct. One player from the offending team must be placed in the penalty box to serve the five minutes major.
- (c) When coincident major penalties are imposed against an equal number of players on each team, the penalized players shall all take their places on the penalty benches and such penalized players shall not leave the penalty bench until the first stoppage of play following the expiration of their respective penalties. Immediate substitutions shall be made for the players so penalized, and their penalties shall not be taken into account for the purpose of the delayed penalty, Rule 30.
- (d) When coincident penalties of equal duration including a major penalty are imposed upon a player of each team, the penalized players shall take their places on the penalty bench and such players shall not leave the penalty bench until the first stoppage of play following the expiration of their respective penalties. Immediate substitution shall be made for the players so penalized and their penalties shall not be taken into account for the purpose of the delayed penalty. Rule 30 or Rule 27.
- (e) When coincident penalties of unequal duration (each including one major penalty) are imposed upon a player of each team, the penalized players shall take their places on the penalty bench and such players shall not leave the penalty bench until the first stoppage of play following the expiration of their respective penalties. The penalties which created the disparity in total penalty time between the players penalized shall be served first in the normal way by the players penalized. Immediate substitution shall be permitted for the major penalties of each player. Account shall be taken of the penalties which create the disparity in the total penalty time awarded to the players affected for the purpose of the delayed penalty, Rule 30 and for Rule 24 (c) (goal scored against a short-handed team).

RULE TWENTY-SIX - MISCONDUCT PENALTIES

- (a) "Misconduct Penalties" to all players except the goalkeeper, involve removal from the game for a period of ten minutes each. A substitute player is permitted to immediately replace a player serving a misconduct penalty. A player whose misconduct penalty has expired shall remain in the penalty box until the next stoppage of play. When a player receives a minor penalty and a misconduct penalty at the same time, the penalized team shall immediately put a substitute player on the penalty bench and the substitute shall serve the minor penalty without charge. When a player receives a major penalty and a misconduct penalty at the same time, the penalized team shall place a substitute player on the penalty bench and no replacement for the penalized player shall be permitted to enter the game except from the penalty bench. Any violation of this provision shall be treated as an illegal substitution under Rule 13 calling for a bench minor penalty.
- (b) A "Game Misconduct Penalty" involves the removal of a player for the balance of the game. A substitute is permitted to replace immediately the player so removed. This penalty shall be reported to the CIRILH Committee which shall have full power to impose further discipline as deemed fitting.
- (c) A Game Misconduct to a player shall result in an automatic one game suspension (immediate next game).
- (d) A second Game Misconduct to a player in the tournament shall result in an automatic match penalty.
NOTE: For all Game Misconduct penalties regardless of when imposed, a total of ten minutes shall be charged in the records against the offending players.
- (e) Any player incurring three (3) stick penalties within a single game will be also assessed a penalty appropriate to the last infraction and be ejected from that game only. A substitute must serve any penalty time that the ejected player was assessed. Stick infractions are: slashing, high sticking, crosschecking, butt ending and spearing.

RULE TWENTY-SEVEN - MATCH PENALTIES

- (a) A "Match Penalty" involves the suspension of a player for the balance of the game, and the offender shall be ordered to the dressing room immediately. A substituted player must be placed on the penalty bench to serve a five minute penalty and may not return onto the floor regardless of goals scored.
NOTE: Regulations regarding additional penalties and substitutions are specifically covered in individual Rules 40-50 and 59; any additional penalty shall be served by a player designated by the manager or coach of the offending team through the playing captain.
NOTE: When coincident match penalties have been imposed under Rule 45 or 59 to a player on both teams, Rule 25 (d) - (e) covering coincident major penalties will not be applicable.
- (b) For all match penalties, regardless of when imposed, or prescribed additional penalties, a total of five minutes shall be charged in the records against the offending player.
- (c) A player incurring a match penalty shall be investigated promptly by the CIRILH Committee which shall have full power to impose such further discipline as deemed fitting.
- (d) A match penalty shall disqualify that player for the remainder of the tournament.

RULE TWENTY-EIGHT - PENALTY SHOT

- (a) When an infraction of the rules calls for a "Penalty Shot", it shall be taken as follows:
The Referee shall cause to be announced over the public address system the name of the player designated by the referee or selected by the team entitled to take the shot (as appropriate) and shall then place the puck on the center face-off spot and the player taking the shot will, on the whistle of the Referee, play the puck from there and shall attempt to score on the goalkeeper. The goaltender must stay in the crease until the referee sounds the whistle. The player taking the shot must keep the puck in motion towards the opponent's goal line and once it is shot the play shall be considered complete. No goal can be scored on a rebound of any kind and any time the puck crosses the goal line the shot shall be considered complete.
- (b) The goalkeeper may attempt to stop the shot in any manner except by throwing a stick or any other object, in which case a goal shall be awarded. NOTE: See Rule 71.
- (c) In cases where a penalty shot has been awarded under Rule 61 (h) (for illegal entry into the game), under Rule 71 (a) (for throwing a stick) and under Rule 74 (for fouling from behind), the Referee shall designate the player who has been fouled as the player who takes the penalty shot.
In cases where a penalty shot has been awarded under Rule 49 (falling on the puck in the crease), or Rule 53 (d) (picking up the puck from the crease area), the penalty shot shall be taken by a player selected as the Captain of the non-offending team from the players on the floor at the time when the foul was committed. Such selection shall be reported to the Referee and cannot be changed.
If by reason of injury the player designated by the Referee to take the penalty shot is unable to do so within a reasonable time, the shot may be taken by a player selected by the Captain of the non-offending team from the players on the floor when the foul was committed. Such selection shall be reported to the Referee and cannot be changed.
- (d) Should the player to whom a penalty shot has been awarded, also have committed a foul in connection with the same play or circumstances, either before or after the penalty has been awarded, and is designated to take the shot, the player shall first be permitted to do so before being sent to the penalty bench to serve the penalty.
If at the time a penalty shot is awarded and the goalkeeper of the penalized team has been removed from the floor to substitute another player, the goalkeeper shall be permitted to return to the floor before the penalty shot is taken.
- (e) If a goal is scored from a penalty shot, the puck shall be faced at center floor in the usual way. If a goal is not scored the puck shall be faced at either of the end face-off spots in the zone in which the penalty shot has been tried.

- (f) Should a goal be scored from a penalty shot, a further penalty to the offending player shall not be applied unless the offense for which the penalty shot was awarded was such as to incur a major or match penalty, in which case the penalty prescribed, for the particular offense, shall be imposed.
If the offense for which the penalty shot was awarded was such as would normally incur a minor penalty, then regardless of whether the penalty shot results in a goal or not, no further minor penalty shall be served.
- (g) If the foul upon which the penalty shot is based occurs during actual playing time the penalty shot shall be awarded and taken immediately in the usual manner notwithstanding any delay occasioned by a slow whistle by the Referee to permit the play to be completed which delay results in the expiration of the regular playing time in any period.
- (h) All players, except player taking penalty shot, must go to the player bench.
- (i) If an opposing player other than the goalkeeper interferes with a player taking a penalty shot, a goal will be automatically awarded whether or not goal was made.
The time required for the taking of a penalty shot will not be included in the regular playing time or any overtime.

RULE TWENTY-NINE - GOALKEEPER PENALTIES

- (a) A goalkeeper shall not be sent to the penalty bench for an offense which incurs a minor penalty, but instead the minor penalty shall be served by a player to be designated by the Coach or Manager of the offending team through the playing Captain and such substitute shall not be changed.
- (b) A goalkeeper shall not be sent to the penalty bench for an infraction of the rules which calls for a major penalty, but instead the major penalty shall be served by a player to be designated by the manager or coach of the offending team through the playing Captain and such substitute shall not be changed.
- (c) Should a goalkeeper incur a misconduct penalty, this penalty shall be served by another team member who was on the floor when the offense was committed, said player to be designated by the manager or coach of the offending team through the playing Captain.
- (d) Should a goalkeeper incur a game misconduct penalty, the goalkeeper's place will be taken by a team member, or by a regular substitute goalkeeper who is available, and such player will be allowed the goalkeeper's full equipment.
- (e) Should a goalkeeper incur a match penalty, the goalie's place will then be taken by a team member or by a substitute goalkeeper who is available, and such player will be allowed the goalkeeper's equipment. A ten minute time period shall be allowed for this change. However, any additional penalties as specifically called for by the individual rules covering match penalties, will apply, and the offending team shall be penalized accordingly; such additional penalty to be served by another member of the team on the floor at the time the offense was committed, said player to be designated by the manager or coach of the offending team through the playing Captain (see Rules 40, 45 and 59).
- (f) When a goalkeeper leaves the immediate vicinity of the goal crease and takes part in any altercation, the goalie shall be given a game misconduct penalty.
NOTE: All penalties imposed on a goalkeeper regardless of who serves the penalty or any substitution, shall be charged in the records against the goalkeeper.
- (g) If a goalkeeper participates in the play in any manner, when the goalie is beyond the center line, a minor penalty shall be imposed on that player.
- (h) Any player (including goalkeeper) who deliberately displaces the goal post to prevent a breakaway scoring opportunity by the opposing team or deliberately displaces the goal post during an ideal scoring opportunity by the opposing team, will result in a penalty shot awarded to the opposing team. If the infraction takes place while the goalie has been replaced in the game for an extra attacker, an automatic goal shall be awarded.

RULE THIRTY - DELAYED PENALTIES

- (a) If a third player of any team shall be penalized while two players of the same team are serving penalties, the penalty time of the third player shall not commence until the penalty time of one of the two players already penalized shall have elapsed. Nevertheless, the third player penalized must, at once, proceed to the penalty bench but may be replaced by a substitute until such time as the penalty time of the penalized player shall commence.
- (b) When any team shall have three players serving penalties at the same time and because of the delayed penalty rule, a substitute for the third offender is on the floor, none of the three penalized players on the penalty bench may return to the floor until play has been stopped. When play has been stopped, the player whose full penalty has expired, may return to the play.
However, the Penalty Timekeeper shall permit the return to the floor in the order of expiration of their penalties, of a player or players by reason of the expiration of their penalties and, the penalized team is entitled to have more than four players on the floor.
- (c) In the case of delayed penalties, the Referee shall instruct the Penalty Timekeeper that penalized players whose penalties have expired shall only be allowed to return to the floor when there is a stoppage of play. When the penalties of two players of the same team will expire at the same time the Captain of that team will designate to the Referee which of such players will return to the floor first, and the Referee will instruct the Penalty Timekeeper accordingly. When a major and a minor penalty are imposed at the same time on players of the same team the Penalty Timekeeper will record the minor as being the first of such penalties.
NOTE: This applies to the case where the two penalties are imposed on DIFFERENT players of the same team (see also NOTE to Rule 24).
- (d) When a delayed penalty is in the process of being assessed to a team that is already shorthanded because of a

previous minor or a bench minor penalty, and the non-offending team scores a goal, the original penalty is terminated which caused the offending team to be short a player and the new penalty is assessed to the offending team, which plays again shorthanded.

RULE THIRTY-ONE - CALLING OF PENALTIES

- (a) Should an infraction of the rules which would call for a minor, major or match penalty be committed by a player of the side in possession of the puck, the Referee shall immediately blow a whistle and give the penalties to the deserving players.
The resulting face-off shall be made at the face-off spot nearest where the play stopped or at center floor so as not to disadvantage the non-offending team.
- (b) Should an infraction of the rules which call for a minor, major, misconduct, or match penalty be committed by a player of the team not in possession of the puck, the Referee shall signify the calling of a delayed penalty by using a raised right arm straight above the head and, on completion of the play by the team in possession or the loss of possession to the defending team, the Referee will immediately blow a whistle and assess the penalty to the offending player.
The resulting face-off shall be made at the nearest face-off spot to where the play stopped or at center floor so as not to disadvantage the non-offending team.
If the penalty to be imposed is a minor penalty, and a goal is scored on the play by the non-offending team the minor penalty shall not be imposed, but major and match penalties shall be imposed in the normal manner regardless of whether a goal is scored or not. (The penalty shall be recorded by the scorekeeper.)
NOTE: "Completion of the play by the team in possession." This rule means that the puck must have come into the possession and control of an opposing player or has been "frozen." This does not mean a rebound off the goalkeeper, the goal cage or any accidental contact with the body or equipment of an opposing player.
NOTE: If after the Referee has signaled a penalty but before the whistle has been blown the puck shall enter the goal of the non-offending team as the direct result of the action of a player of that team, the goal shall be allowed and the penalty signaled shall be imposed in the normal manner.
NOTE: If when a team is "short-handed" by reason of one or more minor or bench minor penalties the Referee signals a further minor penalty against the "short-handed" team and a goal is scored by the non-offending side before the whistle is blown then the delayed penalty shall be served and the first of the minor penalties already being served shall automatically terminate under Rule 24 (c).
- (c) Should the same offending player commit other fouls on the same play either before or after the Referee has blown a whistle, the offending player shall serve such penalties consecutively.
- (d) If a team has a delayed minor penalty and that team is scored upon during the delayed penalty, the penalty shall not be assessed, but it shall be so recorded and count in the offending player's penalty total. If the delayed penalty is major, then that penalty will be assessed.

SECTION V

RULE THIRTY-TWO - APPOINTMENT OF OFFICIALS

- (a) The CIRILH Committee shall appoint the best referees available.
- (b) All Referees and competition officials must be treated with courtesy at all times during the tournament by all players and delegates from all countries. Any infraction of this rule will be reported to the CIRILH Committee which may assess such penalties as the infraction warrants.
- (c) Two Referees will be used in all championship games, one of which will be named by the CIRILH Committee as the Chief Referee. They shall have similar duties, but in areas of controversy the decision of the Chief Referee will be final.
- (d) A Chief Referee shall have full authority and final decision in all matters of dispute. The Chief Referee's decision shall be final on all questions of fact and not subject to appeal.
- (e) A Referee shall not be considered for use in any championships unless recommended in writing by the National Federation or appointed by the CIRILH Committee.
NOTE: All letters of recommendation for Referees must be forwarded to the CIRILH Committee for approval.
NOTE: All Referees operating within the jurisdiction of the CIRILH Committee must be affiliated with a National Federation and have a valid hockey referee commission card.

RULE THIRTY-THREE - REFEREE

- (a) The Referees are the official representatives of the CIRILH Committee. They shall be in full control of players on and off the floor. Minor officials and the officials connected with the competing clubs and the Referees will be backed to the limit in all legitimate circumstances.
- (b) The Referees shall see that the teams are called to the floor at the appointed time for the commencement of each game, and at the start of each regulation and overtime period. The Referees shall remain on the floor at the conclusion of each period, and any overtime, until the players have proceeded to their benches or dressing room.
- (c) The Referees shall check the equipment worn by any player when requested to do so by the manager or coach of either team.
- (d) The Referees shall assess all penalties as prescribed by the rules for the infractions thereof.

- (e) The Chief Referee shall have the final decision on all goals, disputed or not and may consult with the other referee and goal judge (if used) before giving the final decision.
- (f) Before starting the game, the Referees shall see that the appointed game timekeeper, penalty timekeeper, official scorer and goal judges are in their respective places.
- (g) The Referees shall report to the official scorer the duration and type of the penalties and the rule infractions involved, and also to whom the goals and assists are to be credited.
- (h) After each game, the Referees shall check and sign the official game report, secure signatures of both team captains and return it to the official scorer.
- (i) If a Referee cannot appear for the match the CIRILH shall appoint another referee.
- (j) If the regularly scheduled appointed officials appear during the progress of the game they may or may not replace the substituted officials, which shall be a decision made by the CIRILH representatives present.
- (k) The Referees in charge shall be a thoroughly disinterested party.
- (l) All Referees shall be dressed in dark blue or black trousers, a striped shirt or attire and equipped as approved by the CIRILH Committee.
- (m) Referees are required to report on the official game report all misconduct and gross misconduct and match penalties immediately following the game involved giving full details to the CIRILH Committee. Such reports are to be confidential.

RULE THIRTY-FOUR - GOAL JUDGES

1. GOAL JUDGES (optional)

- (a) There shall be one goal judge behind each goal. They shall not be members of either competing team nor shall they be replaced during the progress of the game unless it becomes apparent that either goal judge on account of partisanship or any other cause is guilty of giving unjust decisions. In such cases the Chief Referee may appoint another goal judge to act in that person's place.
- (b) Each goal judge must be stationed in the designated area behind the goal and off the playing surface for the duration of the game and shall not change ends at any time after the games begins. Their jurisdiction is limited to that game only.
- (c) In the event of a goal being claimed, the goal judge of that goal shall indicate whether or not the puck has passed between the goal posts and entirely over the goal line. This decision will simply be goal or no goal.
NOTE: See Rule 33 (e).
- (d) The use of goal judges and their positioning will be at the discretion of CIRILH.

2. DUTIES OF A GOAL JUDGE

- (a) To extend both hands above the head when the puck has completely passed over the goal line between the goal posts.
- (b) The Goal Judge must keep an accurate count of saves by the goalie.
NOTE: A save is only when a goal would be scored except the goalie stopped it.
- (c) The goal judge should assist the Referee on a decision as to whether an opposing player was in the crease before the puck entered the crease.
- (d) Check the net to make sure there are no holes that the puck can get through.
- (e) See that at all times the goal cage is kept in its correct position of the floor.
- (f) When the goalie has frozen the puck and it becomes unplayable the goal judge should extend one arm above the head to signal to the Referee.
- (g) If a shot is made on goal which does not score, goal judges are to extend their arms straight out from their sides.

RULE THIRTY-FIVE - PENALTY TIMEKEEPER

- (a) The penalty timekeeper shall keep the time served by each penalized player during the game and upon request inform the penalized player of the unfinished penalty time.
- (b) If a player leaves the penalty bench before the penalty time has expired, the penalty timekeeper shall note the time and signal the Referee who will stop the play as soon as possible.
- (c) Where public address systems are used, the penalty timekeeper shall announce or have announced the name of each penalized player, the nature of the offense and the penalty assessed.

RULE THIRTY-SIX - OFFICIAL SCORER

- (a) The official scorer shall enter into the official game report a correct record of the goals scored, who scored, and to whom credit is given for assists, if any. The scorer shall also keep a correct record of all penalties assessed stating the names and numbers of the penalized players, the duration of each penalty, the infraction and the time the penalty was assessed.
- (b) At the completion of each game the official scorer shall sign the official game report and have the Referee and each team captain sign it. This official shall then forward the game report to the designated CIRILH Committee member.
- (c) Prior to the start of the game, the official scorer shall obtain from the manager or coach of each team the complete line-up, verified and signed by the team official in charge. The Captains/Alternate Captains of each team shall be duly noted on the official game report.
- (d) The official scorer shall submit the complete line-up of the competing teams to the Referee prior to the start of the

game, and shall draw to the referee's attention any circumstance which the official believes does not comply with the rules.

- (e) The official scorer shall advise the Referee when the same player has received a second or third penalty or a second misconduct penalty in the same game.
- (f) Where a public address system is used, the official scorer shall announce, or have announced, immediately following the scoring of each goal, the name of the player who scored the goal, and the name of each player who received an assist.

RULE THIRTY-SEVEN - GAME TIMEKEEPER

- (a) The game timekeeper shall record the time of the starting and finishing of each game, and all actual playing time during the game.
- (b) The game timekeeper shall signal the Referee for the commencement of the game, the start of the second period, and for each overtime period.
If the rink is not equipped with an automatic buzzer, gong or siren or if this equipment should fail to operate, the game timekeeper shall, by means of a whistle, signal the end of each period, each overtime period, and the end of the game.
- (c) The game timekeeper shall announce or have announced when TWO MINUTES of actual playing time remains in each regulation or overtime period.
- (d) Record time of scores and penalties at expired time of the period, recording all times in minutes and seconds.

SECTION VI

RULE THIRTY-EIGHT - ABUSE OF OFFICIALS AND OTHER MISCONDUCT

NOTE: In the enforcement of this rule the Referee has, in many instances, the option of imposing a "Misconduct Penalty" or a "Bench Minor Penalty".

In principle the Referee is directed to impose a "Bench Minor Penalty" in respect to the violations which occur on or in the immediate vicinity of the player bench but also off the playing surface, and in all cases affecting non-playing personnel or players.

A "Misconduct Penalty" should be imposed for violations which occur on the playing surface or in the penalty bench area and where the penalized player is readily identifiable.

- (a) A game misconduct shall be imposed on any player who uses obscene, profane or abusive language or gestures to any person or who persists in disputing or shows disrespect for the ruling of any official during a game or who intentionally knocks or shoots the puck out of the reach of an official who is retrieving it.
- (b) A misconduct penalty shall be imposed on players who bang the boards with their sticks or any other equipment at any time.
- (c) A misconduct penalty shall be imposed on penalized players who does not proceed directly and immediately to the penalty box and take the required place on the penalty bench.
Any player who (following a fight or other altercation in which the player has been involved is broken up, and for which the player is penalized) fails to proceed immediately to the penalty bench or who persists in continuing or attempting to continue the fight or altercation or who resists a Referee in the discharge of the referee's duties shall incur a Game Misconduct Penalty.
- (d) A Game Misconduct Penalty shall be imposed on any player who, after warning by the Referee, persists in any course of conduct (including threatening or abusive language or gestures or similar actions) designed to incite an opponent into incurring a penalty.
- (e) In the case of any club executive, manager, coach or trainer being guilty of such misconduct, that person is to be removed from the building and this incident reported to the CIRILH Committee.
- (f) If any manager, coach or trainer is removed from the bench by order of the Referee, that person must not sit near the team bench, nor in any way direct or attempt to direct the play of this team.
- (g) A misconduct penalty shall be imposed against any player using obscene, profane or abusive language to any person or any official.
- (h) A game misconduct penalty shall be imposed against the offending team if any player, manager, coach or trainer in the vicinity of the player bench or penalty bench throws anything on the floor during the progress of the game or during stoppage of play.
- (i) A game misconduct penalty shall be imposed against the offending team if any player, manager, coach or trainer interferes in any manner with any game official including Referee, timekeeper or goal judge in the performance of their duties.

NOTE: The Referee may assess further penalties under this rule or rule 24 (b) if deemed warranted.

- (j) A misconduct penalty shall be imposed on any player or players who, except for the purpose of taking their positions on the penalty bench, enter or remain in the Referees crease while the referee is reporting to or consulting with any game official including timekeeper, penalty timekeeper, official scorer or announcer.

RULE THIRTY-NINE - ADJUSTMENT TO CLOTHING AND EQUIPMENT

- (a) Play shall not be stopped, nor the game delayed by reason of adjustment of clothing, equipment, shoes, skates or sticks.
- (b) For an infringement of this rule, a minor penalty shall be given.
- (c) The responsibility of maintaining clothing and equipment in proper condition shall be upon the player. If adjustments are required, the player shall retire from the floor and play shall continue without interruption using a substitute.
NOTE: In the event a player loses a helmet in the "process of a play" that player will be allowed to continue "that play" but immediately following "that play" the player must retrieve that helmet and immediately fasten that helmet onto his or her head. A violation will result in a two minute minor penalty for improper equipment.
- (d) However, a goalkeeper, after a stoppage of play, with the permission of the Referee, may be allowed to make adjustments or repairs to clothing, equipment, shoes or skates.
Goalkeepers may also be permitted by the Referee to replace their goalie masks but no time shall be allowed for repair or fitting a mask.
- (e) For an infraction of a rule by a goalkeeper, a minor penalty shall be imposed.

RULE FORTY - ATTEMPT TO INJURE

- (a) A match penalty shall be imposed on any player who deliberately attempts to injure an opponent, official, manager, coach or trainer in any manner and the circumstances shall be reported to the CIRILH Committee for further action. A substitute for the penalized player shall be permitted at the end of the fifth minute.

RULE FORTY-ONE - BOARDING

- (a) A minor or major penalty, at the discretion of the Referee based upon the degree of violence of the impact with the boards, shall be imposed on any player who body checks, cross checks, elbows, charges or trips an opponent in such a manner that caused the opponent to be thrown violently into the boards.
NOTE: Any unnecessary contact with a player carrying the puck which results in that player being knocked into the side boards is "boarding" and must be penalized as such. In other instances where there is no contact with the fence it should be treated as "charging."
"Rolling" an opponent (if that player is the puck carrier) along the boards where the player is endeavoring to go through too small an opening is not boarding. However, if the opponent is not the puck carrier, then such action should be penalized as boarding, charging, interference, or if the arms or stick are employed it should be called holding or hooking.

RULE FORTY-TWO - BROKEN STICK

- (a) A player whose stick is broken may participate in the game provided the player immediately drops this stick. A minor penalty shall be imposed for an infraction of this rule.
- (b) A goalkeeper may continue to play with the paddle portion of a broken stick until stoppage of play or until the goalie has been legally provided with a stick.
- (c) A player whose stick is broken may not receive a stick thrown on the floor from any part of the rink, but must obtain one from the player bench. A goalkeeper whose stick is broken may not receive a stick thrown on the floor from any part of the rink but may receive a stick from a teammate without proceeding to the team bench. A minor penalty shall be imposed on the player or goalkeeper receiving a stick illegally under this rule.

NOTE: A broken stick is one which, in the opinion of the Referee, is unfit for normal play.

RULE FORTY-THREE - CHARGING

- (a) A minor or major penalty shall be imposed on a player who runs or jumps into or charges an opponent.
- (b) A major penalty shall be imposed on a player who charges a goalkeeper while the goalkeeper is within the goal crease. If the charging player makes physical contact with the goalie, which in the opinion of the referee interferes with normal defense of the goal, any goal scored before or after such contact shall be disallowed.
A goalkeeper is NOT "fair game" just because the goalie is outside the goal crease area. A penalty for inference or charging (minor or major) should be called in every case where an opposing player makes unnecessary contact with a goalkeeper.

RULE FORTY-FOUR - CROSS CHECKING

- (a) A minor or major penalty at the discretion of the Referee, shall be imposed on a player who "cross checks" an opponent.
- (b) A major penalty shall be imposed on a player who cross checks a goalkeeper while the goalkeeper is within the goal crease.
- (c) A major penalty and a game misconduct penalty shall be imposed on any player who injures an opponent by cross checking.

NOTE: Cross check shall mean a check delivered with both hands on the stick and no part of the stick on the floor.

RULE FORTY-FIVE - DELIBERATE INJURY OF OPPONENTS

- (a) A match penalty shall be imposed on a player who deliberately injures an opponent in any manner.
- (b) No substitute shall be permitted to take the place of the penalized player until five minutes actual playing time shall have elapsed, from the time the penalty was imposed.
- (c) All such instances shall be reported to the CIRILH Committee.
- (d) A Game Misconduct penalty shall be assessed any player guilty of kicking or attempting to kick any part of an opponent's body or skates.

RULE FORTY-SIX - DELAYING THE GAME

- (a) No player or goalkeeper shall delay the game by deliberately shooting or batting the puck outside the playing area. The Referee shall impose a minor penalty, immediately and without warning, against any player or goalkeeper who throws the puck outside the playing area.
- (b) A minor penalty shall be imposed on any player (including goalkeeper) who delays the game by deliberately displacing a goalpost from normal position. Any player (including goalkeeper) who deliberately displaces the goal post to prevent a breakaway scoring opportunity by the opposing team or deliberately displaces the goal post during an ideal scoring opportunity by the opposing team, will result in a penalty shot awarded to the opposing team.
- (c) A bench minor penalty shall be imposed upon any team which, after warning by the Referee to its Captain or Alternate Captain to place the correct number of players on the floor and commence play, fails to comply with the Referee's direction and thereby causes any delay by making additional substitution, or in any other manner.

RULE FORTY-SEVEN - ELBOWING AND KNEEING

- (a) A minor penalty shall be imposed on any player who uses an elbow or knee in such a manner as to in any way foul an opponent.
- (b) A major penalty shall be imposed on any player who injures an opponent as the result of a foul committed by using elbows or knees.

RULE FORTY-EIGHT - FACE-OFFS

- (a) Players facing-off will stand facing their opponent's end of the rink approximately one stick length apart with the full blade of their stick on the floor. All other players must be at least ten feet away from the players facing-off and they must be on-side.
- (b) In the conduct of any face-off anywhere on the playing surface, players shall not make any physical contact with an opponent's body by means of their own body or by their sticks except in the course of playing the puck after the face-off has been completed.
For violation of this rule the Referee shall impose a minor penalty or penalties on the player(s) whose action(s) caused the physical contact.
NOTE: "Conduct of any face-off" commences when the Referee designates the place of the face-off and the puck is dropped.
- (c) If a player facing-off fails to take a proper position immediately when directed by the official, the official may order that player replaced for that face-off by any teammate then on the floor.
- (d) A second violation of any of the provisions or sub-selection(s) hereof during the same face-off may be penalized with a minor Delay of Game penalty to the player who commits the second violation of the rule.
- (e) When an infringement of a rule has been committed or a stoppage of play has been caused by any player of the attacking side, the ensuing face-off shall be made on the center face-off spot.
NOTE: This includes stoppage of play caused by a player of the attacking side shooting the puck on to the back of the defending team's net without any intervening action by the defending team.
- (f) When an infringement of a rule has been committed by players of both sides in the play resulting in the stoppage, the ensuing face-off will be made at the place of such infringement or at the place where play is stopped in cases where play is permitted to be completed unless otherwise expressly provided by these rules.
- (g) When stoppage occurs between the end of face-off spots and near the end of the rink the puck shall be faced-off at the end face-off spot on the side where the stoppage occurs unless otherwise expressly provided by these rules.
- (h) Players must keep their sticks flat on the line for the face-off.
- (i) When a goal is illegally scored as a result of the puck being deflected off the Referee directly into the net, the face-off shall be at either of the face-off spots in that zone.
- (j) When the game is stopped for any reason not specifically covered in the official rules the puck must be faced-off where it was last played.
- (k) The Referee is under no obligation to wait for the players to get to the face-off spot. It is the players' responsibility to get there as quickly as possible. If one team is lined up and the other team is procrastinating the Referee can start the play by dropping the puck.
NOTE: Once a team is in face-off position, the puck could be put into play within five seconds.

RULE FORTY-NINE - FALLING ON PUCK

- (a) A minor penalty shall be imposed on a player other than the goalkeeper who deliberately falls on or gathers a puck into the body.
NOTE: Defensemen who drop to their knees to block shots should not be penalized if the puck is shot under them or becomes lodged in their clothing or equipment but any use of the hands to make the puck unplayable should be penalized promptly.
- (b) A minor penalty shall be imposed on a goalkeeper who (when the goalkeeper's body is entirely outside the boundaries of the goal crease area and when the puck is behind the goal line) deliberately falls on or gathers the puck to the body or who holds or places the puck against the boards.

- (c) No defending player except the goalkeeper will be permitted to fall on the puck or hold the puck or gather the puck into the body or hands when the puck is within the goal crease.
For infringement of this rule play shall immediately be stopped and a penalty shot shall be ordered against the offending team but no other penalty shall be given.
NOTE: This rule shall be interpreted so that a penalty shot will be awarded only when the puck is in the crease at the instant the play is stopped. However in cases where the puck is outside the crease Rule 49 (a) may still apply and a minor penalty may be imposed even though no penalty shot is awarded.

RULE FIFTY - FIGHTING

- (a) A major penalty and game misconduct shall be imposed on any player who starts fighting. Fighting is defined as the actual throwing of a punch(es) with a closed fist by a player who makes actual contact with an opponent. Pushing, shoving or grappling while on skates are punishable offenses, but do not constitute fighting under this rule.
- (b) A minor penalty shall be imposed on a player who having been struck shall retaliate with a blow or attempted blow. However, at the discretion of the Referee, a major or double minor penalty may be imposed if that player continues the altercation.
NOTE: The Referee is provided very wide latitude in the penalties which the referee may impose under this rule. This is done intentionally to enable the referee to differentiate between the obvious degrees of responsibility of the participants either for starting the fighting or persisting in continuing the fighting. The discretion provided should be exercised realistically.
NOTE: Referees are directed to employ every means provided by these rules to stop "brawling" and should use Rule 38 (c) for this purpose unless the coincidental major penalty rule is involved.
- (c) A game misconduct penalty shall be imposed on any player involved in fighting off the playing surface or with another player who is off the playing surface.
- (d) A game misconduct penalty shall be imposed on any player or goalkeeper on the floor who first intervenes in an altercation then in progress.
- (e) Any player assessed a major penalty for fighting will be automatically suspended for the remainder of that game and the next game played by the team.
NOTE: If the suspended player's team draws a bye for their next game, this penalty will be carried over to the next game that the team plays, even if the next game is in another division.
NOTE: The penalized team will place a man in the penalty box and play short-handed for the duration of the major penalty.

RULE FIFTY-ONE - GOAL AND ASSISTS

- (a) A goal shall be scored when the puck has been put between the goal posts by the stick of a player of the attacking side from in front, and below the cross bar and entirely across the line the width of the diameter of the goal posts drawn on the floor from one goal post to the other.
- (b) A goal shall be scored if the puck is put into the goal in any way by a player of the defending side. The player of the attacking side who last played the puck shall be credited with the goal but no assist shall be awarded.
- (c) If an attacking player kicks the puck and it is deflected into the net by any player of the defending side except the goalkeeper, the goal shall be allowed.
The player who kicked the puck shall be credited with the goal but no assist shall be awarded.
- (d) If the puck has been deflected into the goal by a shot of an attacking player by striking any part of the person or a player of the same side, a goal shall be allowed. The player who deflected the puck shall be credited with the goal. The goal shall not be allowed if the puck has been kicked, thrown or otherwise deliberately directed into the goal by any means other than a stick.
- (e) If a goal is scored as a result of a puck being deflected directly into the net from an official, the goal shall not be allowed.
- (f) Should a player legally propel a puck into the goal crease of the opponent's team and the puck should become loose and available to another player of the attacking side, a goal scored on the play shall be legal.
- (g) Any goal scored other than as covered by the official rules shall not be allowed. When a player charges a goalkeeper who is within the goal crease, subsequently makes physical contact with the goalie, and in the opinion of the referee thus interferes with normal defense of the goal, any goal scored before or after such contact shall be disallowed and a major penalty assessed.
- (h) A goal shall be credited in the scoring records to a player who shall have propelled the puck into the opponent's goal.
- (i) When a player scores a goal, an assist shall be credited to the player who made the pass leading to a direct goal in the offensive zone; also when headmanning (a forward pass to a teammate in the direction of the goal) the pass of the puck leading to a breakaway.

RULE FIFTY-TWO - GROSS MISCONDUCT

- (a) The Referee may suspend from the game and order to the dressing room for the remainder of the game any player, manager, coach or trainer guilty of gross misconduct of any kind.
- (b) If a player so dismissed is taking part in the game, the player shall be charged with a game misconduct penalty, and a substitute shall be permitted.
- (c) The Referee in charge is to decide on any violation and report the incident to the CIRILH Committee for further action.
- (d) If a player, coach or manager persists after warning from the Referee in continuing gross misconduct, that person shall be subject to suspension for a period of one year or more as determined by the CIRILH Committee.

RULE FIFTY-THREE - HANDLING PUCK WITH HANDS

- (a) If a player, except the goalkeeper, closes the hand or glove intentionally on the puck, the play shall be stopped and a minor penalty shall be imposed on that player. A goalkeeper who holds the puck with the hands for longer than three seconds may be given a minor penalty, if there are no attacking players in the immediate vicinity.
- (b) A goalkeeper shall not deliberately hold the puck in any manner which in the opinion of the Referee causes a stoppage of play, nor deliberately drop the puck into the goalie pads or onto the goal net, nor deliberately pile up obstacles at or near the net, that in the opinion of the Referee would tend to prevent the scoring of a goal.
NOTE: The object of the entire rule is to keep the puck moving continuously and any action taken by the goalkeeper which causes an unnecessary stoppage must be penalized without warning.
- (c) The penalty for infringement of this rule by the goalkeeper shall be a minor penalty.
NOTE: In the case of a puck thrown forward by the goalkeeper being taken by an opponent, the Referee shall allow the resulting play to be completed. However, should the throw be received by a teammate, the play shall be stopped for a forward hand pass by the goaltender with a face-off resulting.
- (d) A minor penalty shall be imposed on a player, except the goalkeeper who, while play is in progress, picks up the puck by hand from the floor.
If a player, except the goalkeeper, uses hands to pick up the puck from the floor in the crease area while play is in progress, the play shall be stopped immediately and a penalty shot shall be awarded to the non-offending team.
- (e) A player shall be permitted to stop or "bat" a puck in the air with an open hand, or push it along the floor by hand, and the play shall not be stopped unless in the opinion of the Referee the player has deliberately directed the puck to a teammate, in which case the play shall be stopped and the puck faced-off at the spot where the offense occurred.
NOTE: The object of this rule is to ensure continuous action and the Referee should NOT stop play unless the referee is satisfied that the directing of the puck to a teammate was in fact DELIBERATE.
The puck may not be batted with the hand directly into the net at any time, but a goal shall be allowed when the puck has been legally batted and is deflected into the goal off a defending player except the goalkeeper.

RULE FIFTY- FOUR - HIGH STICKS

- (a) The carrying of the blade of the stick above the normal height of the shoulders is prohibited. A minor penalty, at the discretion of the Referee, shall be assessed any player who makes contact with or intimidates an opponent while carrying the stick blade above the shoulders of an opponent. If injury results, a major penalty plus game misconduct penalty shall be assessed. When a stick is swung above the shoulders at a puck near another player, that player shall be called for high sticking and a minor penalty assessed
- (b) When a player carries or holds any part of the stick above the height of the shoulders so that injury to the face or head of an opposing player results, the Referee shall have no alternative but to impose a major penalty plus a game misconduct penalty on the offending player.
- (c) A goal scored from a stick carried above the height of the cross bar of the goal cage shall not be allowed, except by a player of the defending team.
- (d) Using the stick to bat the puck above the normal height of the shoulders is prohibited and when it occurs there shall be a whistle and ensuing face-off at the spot where the offense occurred unless:
- 1) The defending player batted the puck to an opponent in which case the play shall continue, or
 - 2) A player of the defending side batted the puck into his or her own goal in which case the goal shall be allowed.
- (e) When either team is below the numerical strength of its opponent and a player of greater numerical strength causes a stoppage of play by striking the puck with the stick above the height of the shoulders, the resulting face-off shall be made at one of the end face-off spots adjacent to the goal of the team causing the stoppage.
- (f) If the blade of a stick is swung above shoulder height near an opponent, whether to intimidate or to attempt to injure the player, this will result in a major penalty. Injury to an opponent under such circumstances is to be both a major and a game misconduct penalty. At the beginning and ending of a slap shot, the blade may be above shoulder level.
EXCEPTION: No penalty should be assessed when the stick is shifted from one hand to the other over the head so the player can play the puck, unless it endangers another player.
NOTE: No contact on an opponent need occur to call a high sticking penalty, however an opposing player must be in the immediate vicinity to justify a penalty being called.

RULE FIFTY- FIVE – HOLDING

- (a) A minor penalty shall be imposed on a player who holds an opponent with hands, legs, feet or stick or in any other way.
- (b) A major penalty shall be imposed if the action of holding results in injury to the player being held.

RULE FIFTY-SIX - HOOKING

- (a) A minor penalty shall be imposed on a player who impedes or seeks to impede the progress of an opponent by hooking with either end of that player's hockey stick.
- (b) A major penalty shall be imposed on any player who injures an opponent by hooking.
NOTE: When a player is checking another in such a way that there is only stick-to-stick contact, such action is NOT

either hooking or holding. That player may turn the stick down over the opponent's stick.

RULE FIFTY-SEVEN - INTERFERENCE

- (a) A minor penalty shall be imposed on a player who interferes with or impedes the progress of an opponent who is not in possession of the puck, or who deliberately knocks a stick out of an opponent's hand or who prevents a player who has dropped a stick from regaining possession of it or who knocks or shoots any abandoned or broken stick or illegal puck or other debris towards an opposing puck carrier in a manner that could cause that player to be distracted.
NOTE: The last player to touch the puck, other than a goalkeeper, shall be considered the player in possession. In interpreting this rule the Referee should make sure which of the players is the one creating the interference. Often it is the action and movement of the attacking player which causes the interference since the defending players are entitled to "stand their ground" or "shadow" the attacking players. Players of the side in possession shall not be allowed to "run" deliberate interference for the puck carrier.
- (b) A minor penalty shall be imposed if any player on the player bench or on the penalty bench who by means of a hockey stick or parts of the body interferes with the movement of the puck or of any opponent on the floor during the progress of play.
- (c) A minor penalty shall be imposed on a player who, by means of a hockey stick or body, interferes with or impedes the movements of the goalkeeper by actual physical contact, while the goalie is in the crease area unless the puck is already in that area.
- (d) Unless the puck is in the goal crease area, a player of the attacking side not in possession may not stand on the goal crease line or in the goal crease or hold a stick in the goal crease area, and if the puck should enter the net while such a condition prevails, a goal shall not be allowed, and the puck shall be faced in the neutral zone at the face-off spot nearest the attacking zone of the offending team.
- (e) If a player of the attacking side has been physically interfered with by the action of any defending player so as to cause that player to be in the goal crease, and the puck should enter the net while the player so interfered with, is still within the goal crease, the goal shall be allowed.
- (f) If when the goalkeeper has been removed from the floor any member of the same team not legally on the floor including the manager, coach or trainer interferes by means of body or stick or any other object with the movement of the puck or an opposing player, the Referee shall immediately award a goal to the non-offending team.
NOTE: A penalty for interference should be called in every case where an opposing player makes unnecessary contact with the player in possession.
NOTE: The attention of Referees is directed particularly to three types of offensive interference which should be penalized:
- 1) When the defending team secures possession of the puck in its own end and the other players of that team run interference for the puck carrier by forming a protective screen against forecheckers;
 - 2) When a player facing-off obstructs the player's opposite number after the face-off when the opponent is not in possession of the puck;
 - 3) When the puck carrier makes a drop pass and follows through so as to make bodily contact with an opposing player.
- NOTE: All offensive or defensive players may attempt to establish positional territory in front of either goal. The incidental contact that occurs in so doing shall not be considered interference or unnecessary roughness. However, should a player from either team run at an opponent, or make a body check, it is at the discretion of the Referee, to assess a minor penalty for interference, charging or unnecessary roughness.

RULE FIFTY-EIGHT - INTERFERENCE BY SPECTATORS

- (a) In the event of a player being held or interfered with by a spectator, the Referee shall blow the whistle and play shall be stopped, unless the team of the player interfered with is in possession of the puck at the time, then the play shall be allowed to be completed before blowing the whistle, and the puck shall be faced-off at the spot where last played at the stoppage.
NOTE: The Referee shall report to CIRILH for possible disciplinary action, all cases in which a player becomes involved in an altercation with a spectator but no penalty should be imposed.
- (b) In the event that objects are thrown on the floor which interfere with the progress of the game the Referee shall blow the whistle and stop the play, and the puck shall be faced-off at the spot the play is stopped.

RULE FIFTY-NINE – CHECKING FROM BEHIND

- (a) A Major Penalty plus a Game Misconduct shall be assessed any player who intentionally pushes, body-checks or hits an opposing player from behind, any where on the skating surface.
- (b) Where a player is high-sticked, cross-checked, body-checked, hit or propelled in any manner from behind into the boards or goal cage in such a way that the player is unable to defend his or her self, a Match Penalty shall be assessed. NOTE: Referees are instructed not to substitute other penalties when a player is checked from behind in any manner. This rule must be strictly enforced.

RULE SIXTY - KICKING THE PUCK

- (a) Kicking the puck shall be permitted in all zones, but a goal may not be scored by the kick of an attacking player except if an attacking player kicks the puck and it is deflected into the net by any player of the defending side, except the goalkeeper.

RULE SIXTY-ONE - LEAVING THE PLAYER OR PENALTY BENCHES

- (a) No player may leave the player bench at any time to enter an altercation, but substitutions shall be permitted provided the player so substituted does not enter the altercation.
Likewise no player on or near the penalty bench (not on the floor) shall participate in any fight or other altercation with any opposing player on the floor.
- (b) A misconduct penalty shall be imposed on each player violating the rule. The Referee shall report all such infractions to the CIRILH Committee which shall have full power to impose such further penalty as deemed fitting.
- (c) Except at the end of each period, or on expiration of penalty, no player may at any time leave the penalty bench.
- (d) A penalized player who leaves the penalty bench before the player's penalty has expired, whether play is in progress or not, but does not enter an altercation, shall incur an additional minor penalty, after serving the player's unexpired time.
- (e) Any penalized player leaving the penalty bench during the stoppage of play, and entering an altercation shall incur a minor penalty plus a ten minute misconduct penalty, after serving the player's unexpired time.
- (f) If a player leaves the penalty bench before the player's penalty is fully served, the penalty timekeeper shall note the time and signal the Referee who will immediately stop the play.
- (g) In the case of a player returning to the floor before the player's time has expired through an error by the penalty timekeeper, that player is not to serve an additional penalty, but must serve the player's unexpired time.
- (h) If a player of an attacking side in possession of the puck shall be in such a position as to have no opposition between that player and the opposing goalkeeper, and while in such position that player shall be interfered with by a player of the opposing side who shall have illegally entered the game, the Referee shall award a penalty shot against the side to which the offending player belongs.
- (i) If the opposing goalkeeper has been removed and an attacking player in possession of the puck shall have no player of the defending team to pass and a stick or a part thereof is thrown by an opposing player or the player is fouled from behind thereby being prevented from having a clear shot on an open goal, a goal shall be awarded against the offending team.
If when the opposing goalkeeper has been removed from the floor, a player of the side attacking the unattended goal is interfered with by a player who shall have entered the game illegally, the Referee shall immediately award a goal to the non-offending team.
- (j) Any non-playing coach, trainer or manager who gets on the floor after the start of the game without permission of the Referee shall automatically be suspended from the game.
- (k) If a penalized player returns to the floor from the penalty bench before the player's penalty has expired by the player's own error or the error of the penalty timekeeper, any goal scored by the player's own team while that player is illegally on the floor shall be disallowed, but all penalties imposed on either team shall be served as regular penalties.
- (l) If a player illegally enters the game from the player's own player bench, any goal scored by the player's own team while that player is illegally on the floor shall be disallowed, but all penalties imposed against either team shall be served as regular penalties.

RULE SIXTY-TWO – PHYSICAL ABUSE OF OFFICIALS

- (a) Any player who touches or holds a Referee, or any game official, with the player's hand or stick or trips or body checks any such officials, shall automatically receive a minimum ten minute penalty for misconduct for the first offense, and a minimum game misconduct penalty for a second offense, in the same game. Depending upon the incident a match penalty may be called. The use of a substitute for the player so suspended shall be permitted.
- (b) Any player who holds or strikes an official shall constitute a match penalty and shall be suspended from the remainder of the tournament.
- (c) Any manager, coach or trainer who holds or strikes an official, shall be automatically suspended from the game, ordered to the dressing room, and disciplinary action shall be taken by the CIRILH Committee.

RULE SIXTY-THREE - OBSCENE OR PROFANE LANGUAGE OR GESTURES

- (a) Players shall not use obscene or profane language or gestures on the floor or anywhere in the rink. For violation of this rule a misconduct penalty shall be imposed except when the violation occurs in the vicinity of the player bench in which case a bench minor penalty shall be imposed.
- (b) Managers, coaches and trainers shall not use obscene or profane language or gestures anywhere in the rink. For violation of this rule a bench minor penalty shall be imposed.
NOTE: It is the responsibility of all game of officials and all team officials to send a confidential report to the CIRILH Committee setting out the full details concerning the use of obscene gestures by any player, coach or other official. The CIRILH Committee shall take further disciplinary action as deemed appropriate.

RULE SIXTY-FOUR - PUCK OUT OF BOUNDS OR UNPLAYABLE

- (a) When the puck goes outside the playing area to either end, or either side of the rink or strikes any obstacles above the playing surface other than the boards, glass or wire it shall be faced-off from where it was shot or deflected, unless otherwise expressly provided in these rules.
- (b) When the puck becomes lodged in the netting on the outside of either goal so as to make it unplayable, or if it is frozen between opposing players intentionally or otherwise, the Referee shall stop the play and face-off the puck at either of the adjacent face-off spots unless in the opinion of the Referee, the stoppage was caused by a player of the attacking team, in which case the resulting face-off shall be conducted at the nearest face-off spot adjacent to the goal of the offending player or center line face-off spots.
NOTE: This includes stoppage of play caused by the player of the attacking side shooting the puck onto the back of

the defending team's net without any intervening action by the defending team.

The defending team and/or the attacking team may play the puck off the net at any time. However should the puck remain on the net for longer than three seconds play shall be stopped and a face-off shall take place in the end face-off zone except when the stoppage is caused by the attacking team, then the face-off shall take place on the face-off spot at the center circle.

- (c) A minor penalty shall be imposed on a goalkeeper who deliberately drops the puck on the goal netting to cause a stoppage of play.
- (d) If the puck comes to rest on top of the boards surrounding the playing area it shall be considered to be in play and may be played legally by hand or stick.

RULE SIXTY-FIVE - PUCK MUST BE KEPT IN MOTION

- (a) The puck must be kept in motion at all times.
- (b) With the exception of being able to carry the puck behind its own goal one time, a team in its own defense area which is in possession of the puck shall always advance the puck toward the opposing goal, except when prevented from doing so by players of the opposing side or if that team in possession is short-handed.
For the first infraction of this rule play shall be stopped and a face-off will be taken at the spot adjacent to the goal of the team causing the stoppage and the Referee shall warn the Captain or Alternate Captain or the offending team of the reason for the face-off. For a second violation by any player of the same team in the same period a minor penalty shall be imposed on the player violating the rule.
- (c) A minor penalty shall also be imposed on any player who deliberately holds the puck against the boards in a manner unless the player is being checked by an opponent.
- (d) For an infringement of this rule the face-off shall be at the nearest end face-off spot adjacent to the offender's goal.

RULE SIXTY-SIX - PUCK OUT OF SIGHT AND ILLEGAL PUCK

- (a) Should a scramble take place or a player accidentally falls on the puck and the puck is out of sight of the Referee, the Referee shall immediately blow the whistle and stop play. There will be a face-off at the nearest face-off spot.
- (b) If at any time while play is in progress a puck other than the one legally in play shall appear on the playing surface the play shall not be stopped but shall continue with the legal puck until the play in progress is completed by change of possession. At the Referee's discretion if the legal puck is interfered in play, the Referee shall stop the play immediately.

RULE SIXTY-SEVEN - REFUSING TO START PLAY AND FORFEITURE

- (a) If when both teams are on the floor one team for any reason shall refuse to play when ordered to do so by the Referee, the referee shall warn the Captain or Alternate Captain and allow the team so refusing fifteen seconds within which to begin the game or resume play. If at the end of that time the team shall still refuse to play the Referee shall impose a two minute penalty on a player of the offending team to be designated by the manager or coach of that team through the Captain. Should there be a repetition of the same incident the Referee shall have no alternative but to declare that the game be forfeited to the non-offending club and the case shall be reported to the CIRILH Committee for further action.
- (b) If a team when ordered to do so by the Referee through its manager or coach fails to go on the floor and start within five minutes, the game shall be forfeited and the case shall be reported to the CIRILH Committee for further action.
- (c) A forfeiture of a game shall be declared for the following reasons:
 - 1) At the start of a game (referee's whistle to put puck in play) a team does not have four skaters and a goalie on the floor in full and required uniform.
 - 2) By the team captain submitting in writing and accepted by meet director that the team will not be able to play a particular game. In this event the opposing team does not need to suit up or make appearance at the game, but shall still be awarded the victory.
 - 3) Due to injury or illness during the game a team cannot field (when at full strength) four skaters and a goalie to continue this game.
- (d) In the event of a forfeit then the following scoring statistics shall be awarded:
 - 1) The forfeiting team shall be awarded a loss for the game. The opposing team shall be awarded two points (a victory for the game). The score of the game shall be recorded as 1 to 0. The forfeiting team (loser), while still in round-robin play, shall be penalized a minus 2 points for that game, which must be deducted from their accumulated points total for the round robin.
 - 2) The Captain of the victorious team shall be awarded one goal. (This may not be substituted to any other player.) There shall be no assists awarded.
 - 3) The goalies of either team shall not be assessed with a shot, save or goal against.
- (e) A team may forfeit one game during the round-robin portion of the tournament without disqualification of that team for the tournament. If the same team forfeits a second game at a tournament, that team shall be disqualified for the remainder of all tournament games. Any single forfeiture occurring after completion of round-robin games, during either the medal play or the placement games, will also cause a team to be disqualified for the remainder of the tournament.
- (f) In the event of the removal of a team from the tournament by forfeiture the following statistical change shall take place:
 - 1) All statistics of the removed team and team players shall be removed from the official stats. This is to include all team points, all goals scored, assists, saves, goals against, penalty minutes and all other pertinent statistics.
 - 2) Any and all teams that have already played the forfeiting team must also have the stats erased as though the game had not been played.

NOTE: The removal of all penalty minutes will not remove action taken or to be taken by the meet director or the committee as to major penalties, game misconduct, ten minute miscellaneous or match penalties that were imposed on forfeiting team players.

NOTE: The CIRILH Committee shall issue instructions pertaining to records, etc. of a forfeited game.

RULE SIXTY-EIGHT - SLASHING

- (a) A minor or major penalty at the discretion of the Referee shall be imposed on any player who impedes or seeks to impede the progress of an opponent by "slashing" with the player's stick. Any stick to body contact enacted by the pursuing player will be considered slashing. No matter how hard the stick to body contact is, it shall be considered a minor penalty.
- (b) A major penalty and a game misconduct penalty shall be imposed on any player who injures an opponent by slashing. When a major penalty is imposed under this rule for a foul resulting in injury to the face or head of an opponent, an automatic major penalty shall be imposed.
NOTE: Referees should penalize as slashing any player who swings the player's stick at any opposing player (whether in or out of range) without actually striking that player or where a player on the pretext of playing the puck makes a wild swing at the puck with the object of intimidating an opponent.
- (c) Any player who swings the player's stick at another player in the course of any altercation shall be subject to a match penalty to be imposed by the Referee. This is considered a deliberate attempt to injure and therefore must be dealt with according to Rule 40.
- (d) Any player not in possession of the puck cannot have any stick contact upon the goalkeeper or it will be considered a slashing penalty.
NOTE: The Referee shall impose the normal appropriate penalty provided in the other sections of this rule and shall in addition report promptly to the CIRILH Committee all infractions under this section.

RULE SIXTY-NINE – SPEARING AND BUTT-ENDING

- (a) A Double Minor Penalty shall be imposed on a player who spears or attempts to spear or butt ends an opponent.
NOTE: "Attempt to spear" shall include all cases where a spearing gesture is made regardless of whether bodily contact is made or not.
- (b) A Match Penalty shall be imposed on any player who injures an opponent by spearing or butt-ending. This should be treated as a deliberate attempt to injure under Rule 45.
NOTE: "Spearing" shall mean stabbing an opponent with the point of the stick blade while the stick is being carried with one hand or with both hands.

RULE SEVENTY - START OF GAME AND PERIODS

- (a) The game shall be commenced at the time scheduled by a "face-off" in the center of the rink and shall be renewed promptly at the conclusion of each intermission in the same manner.
No delay shall be permitted by reason of any ceremony, exhibition, demonstration or presentation unless consented to reasonably in advance by the meet director.
- (b) Home clubs shall have the choice of goals to defend at the start of the game. Where both player benches are on the same side of the rink, the home club shall start the game using that bench farthest from its starting goal. The team will not change benches for a new period.
- (c) During the pre-game warm-up and before the commencement of play in any period, each team shall confine its activity to its own end of the rink.
NOTE: All players must be dressed and ready to play ONE HOUR prior to their scheduled playing time, or game will be forfeited.
- (d) All players must be in full uniform to take the floor for warm-ups.

RULE SEVENTY-ONE - THROWING STICK

- (a) When any player of the defending side, including the goalkeeper, deliberately throws the player's stick or any part thereof or any other object, at the puck in the player's defending zone, the Referee shall allow the play to be completed and if a goal is not scored a penalty shot shall be awarded to the non-offending side, which shot shall be taken by the player designated by the Referee as the player fouled.
If, however, the goal is unattended and the attacking player has no defending player to pass and has a chance to score on an open net, a goal shall be awarded to the attacking side.
- (b) A major penalty shall be imposed on any player who throws the player's stick, of any part thereof or any other object, in any area except when such an act has been penalized by the award of a penalty shot on goal.
NOTE: When a player discards the broken portion of a stick by tossing it to the side of the floor (and not over the boards) in such a way as will not interfere with play or opposing player, no penalty will be imposed for doing so.

The Referee shall report promptly to the CIRILH Committee for disciplinary action every case where a stick or any part thereof is thrown outside the playing area.

RULE SEVENTY-TWO - GAME TIME AND TIME OUTS

- (a) The game shall be played in two 20 minute periods with a five-minute rest permitted between each period, after which the teams shall change ends. For games where a tie is not desirable, at the conclusion of the tied match, a three (3) minute rest will be allowed, and the teams will begin a sudden death play-off. If no team has scored after ten (10) minutes, the teams will be given a three (3) minute rest, change ends and begin another ten (10) minute period. This

- shall continue until a winner is determined.
- (b) Any overtime period shall be considered a part of the game and all unexpired penalties shall remain in force
 - (c) A time-out may be called only by a player in possession of the puck, or by the Captain or Alternate Captain when the puck has been whistled dead. Resume play by a face-off.
 - (d) One time-out of one-minute duration for each team per half will be available. A game time out may be called by the Referee at any time during the game.
 - (e) When there is a time-out, the teams may go to the player bench.
 - (f) No time-outs in an overtime game or sudden death.
 - (g) Any violations of the above rule will result in a two (2) minute minor penalty.

RULE SEVENTY-THREE - TIED GAMES

- (a) If, at the end of the game, the score is tied, the game shall be called a "TIE" and each team shall be credited with one point in the standings, except for single elimination matches where ties are not desirable at the end of regular playing time, then Rule 73(b) will be used.
- (b) Games where a tie is not desirable (pre-quarter finals, quarter-finals, semi-finals and finals or other types of single elimination competitions), a tie will be decided as follows: At the conclusion of the tied match, a three (3) minute rest will be allowed, and the teams will begin a sudden death play-off, with the announcement that the first team to score will be declared the winner. If no team has scored after ten (10) minutes, the teams will be given a three (3) minute rest, then change ends, and begin another ten (10) minute period. This shall continue until a winner is determined.
- (c) **Shoot-Out:** In determining seeds following "round robin" play, or in other appropriate circumstances determined by CIRILH or the meet director, when additional game time is not available for sudden death overtime, a shoot-out can be used to break ties for teams having equal accumulated points. Shoot-outs will take place using four shooters from each team, with each team alternately participating, in conformity with procedures as outlined in Rule 28 for penalty shots. Team captains will use a coin toss prior to the start of the shoot-out to determine which team will initiate the alternating sequence of shots. Each goalie will defend that team's own goal and a common goal cage is not to be employed. The highest number of successful goals obtained from the four attempts will determine the victor in the shoot-out. If after the first round, a tie still exists, additional shots will be attempted by each team under a sudden death format, allowing each team the same total number of attempts. No player from a participating team may shoot again until all players on the active roster, excluding goalies, have participated.

RULE SEVENTY-FOUR - TRIPPING

- (a) A minor penalty shall be imposed on any player who shall place the player's stick, knee, foot, arm, hand or elbow in such a manner that it shall cause the player's opponent to trip or fall.
NOTE: If in the opinion of the Referee a player is unquestionably hook-checking the puck, and obtains possession of it thereby tripping the puck carrier, no penalty shall be imposed.
- (b) When a player, in control of the puck in the attacking zone, and having no other opponent to pass than the goalkeeper, is tripped or otherwise fouled from behind preventing a reasonable scoring opportunity a penalty shot shall be awarded to the non-offending side. Nevertheless the Referee shall not stop the play until the attacking side has lost possession of the puck to the defending side.

NOTE: The intention of this rule is to restore a reasonable scoring opportunity which has been lost by reason of a foul from behind when the foul is committed in the attacking zone.

"Control of the puck" means the act of propelling the puck with the stick. If, while it is being propelled, the puck is touched by another player or the player's equipment or hits the goal or goes free, the player shall no longer be considered to be "in control of the puck."

- (c) If, when the opposing goalkeeper has been removed from the floor, a player in control of the puck is tripped or otherwise fouled with no opposition between that player and the opposing goal, thus preventing a reasonable scoring opportunity, the Referee shall immediately stop the play and award a goal to the attacking team.

RULE SEVENTY-FIVE - UNNECESSARY ROUGHNESS

- (a) At the discretion of the Referee, a Minor Penalty may be imposed on any player deemed guilty of unnecessary roughness.
- (b) A Major Penalty shall be assessed if the action of roughing results in an injury to the player being roughed.
NOTE: It is not intended that there be no body contact between two opposing players who are actively in pursuit of the puck. The act of riding an opponent off the puck, or meeting the opponent head-on, while attempting to play the puck, shall not be considered roughness. However, this does not imply that players NOT in possession of the puck may throw their bodies into an opponent in order to achieve possession.
NOTE: Penalty for unnecessary roughness (roughing) should be called in every case when an opposing player makes unnecessary contact with the player in possession.

PENALTY INDEX

Abuse of Officials	Rule 38
Adjustment of Equipment	Rule 39
Attempt to Injure	Rule 40
Board Checking	Rule 41

Broken Stick	Rule 42
Butt-Ending	Rule 69
Charging	Rule 43
Checking from Behind	Rule 59
Cross Checking	Rule 44
Deliberate Injury	Rule 45
Delay of Game	Rule 46
Elbowing	Rule 47
Face-off	Rule 48
Falling on Puck	Rule 49
Fighting	Rule 50
Goalkeepers Equipment	Rule 17
Goalkeepers Penalties	Rule 29
Gross Misconduct	Rule 52
Handling Puck	Rule 53
High Stick	Rule 54
Holding	Rule 55
Hooking	Rule 56
Illegal Substitution	Rule 61
Change of Players	Rule 13
Interference	Rule 57
Interference by Spectator	Rule 58
Kick Puck	Rule 60
Kicking Opponent	Rule 45
Kneeing	Rule 47
Leaving Bench	Rule 61
Physical Abuse of Officials	Rule 62
Obscene Language	Rule 63
Puck in Motion	Rule 65
Refusing to Start Play	Rule 67
Slashing	Rule 68
Spearing	Rule 69
Throwing Stick	Rule 71
Tripping	Rule 74
Unnecessary Roughness	Rule 75
Unplayable Puck	Rule 64

QUICK REFERENCE INDEX FOR PENALTIES - Minor 2 Minutes

Abuse of Officials	Rule 38
Adjustment Equipment	Rule 39
Boarding	Rule 41
Broken Stick	Rule 42
Butt-Ending	Rule 69
Charging	Rule 43
Cross Checking	Rule 44
Dangerous Equipment	Rule 19
Delay of Game	Rule 46
Elbowing	Rule 47
Face-off	Rule 48
Falling on Puck	Rule 49
Fighting	Rule 50
Goalkeepers Equipment	Rule 17
Goalkeepers Penalties	Rule 29
Handling Puck	Rule 53
High Stick	Rule 54
Hooking	Rule 56
Holding	Rule 55
Illegal Substitution	Rule 13, Rule 61(h)
Interference	Rule 57
Kneeing	Rule 47
Leaving Penalty Bench Early	Rule 61(d)
Refusal to Start Play	Rule 67
Slashing	Rule 68
Sticks	Rule 15
Tripping	Rule 74
Unnecessary Roughness	Rule 75

DOUBLE MINOR (2 MINOR PENALTIES)

Butt-Ending	Rule 69
Spearing	Rule 69

MAJOR 5 MINUTES

Attempt to Injure	Rule 40
Boarding	Rule 41
Charging	Rule 43
Checking from Behind	Rule 59
Cross Checking	Rule 44
Elbowing	Rule 47
Fighting	Rule 50
High Stick	Rule 54
Holding Causing Injury	Rule 55(b)
Hooking Causing Injury	Rule 56(b)
Kneeing	Rule 47(b)
Slashing	Rule 68
Throwing Stick	Rule 71(b)
Unnecessary Roughness With Resulting Injury	Rule 75(b)

MISCONDUCT PENALTIES 10 MINUTES

Abuse of Officials	Rule 38
Banging Boards	Rule 38(b)
Broken Stick	Rule 42
Complaint About a Penalty	Rule 10(g)
Leaving Player or Penalty Bench to Fight	Rule 61(b)(e)
Misconduct Penalties	Rule 26
Physical Abuse of Officials	Rule 62
Obscene Language	Rule 63 & 38 (g)
Resistance to Serve Penalty	Rule 38(c)
Third Minor Penalty	Rule 24(a)
Trespass in Referee Crease	Rule 38 (j)

GAME MISCONDUCT - SUSPENSION

Abuse of Officials	Rule 38(d)
Checking from Behind	Rule 59
Cross Check Injury	Rule 44(c)
High Stick Injury	Rule 54
Incite Opponent after warning	Rule 38 (d)
Interfere with Official	Rule 38(i)
Kicking Opponent	Rule 45(d)
Goalie leaves goal crease for Altercation	Rule 29(f)
Gross Misconduct	Rule 52
Fighting	Rule 50(a)(c)(d)
Obscene Language	Rule 38(a)
Physical Abuse of Officials	Rule 62
Resists Referee in Duties	Rule 38C
Second Major Penalty	Rule 25 (b)
Slashing with Injury	Rule 68(b)
Stick Swung above shoulder	Rule 54 (f)
Throwing on Skating Floor	Rule 38(h)
Three Stick Penalties	Rule 26 (no subsequent game suspension)

MATCH PENALTY 5 MINUTES

Attempt to Injure	Rule 40
Butt-Ending	Rule 69
Checking From Behind	Rule 59
Deliberate Injury	Rule 45
Physical Abuse of Official	Rule 62(a)
Second Misconduct	Rule 26 (d)

Slashing during Altercation	Rule 68(c)
Spearing	Rule 69

PENALTY SHOT

Displacing Goal	Rule 46(b)
Falling on Puck in Crease	Rule 49
Fouling from the Rear	Rule 74(b)
Illegal Player	Rule 61 (h)
Picking up Puck in Crease	Rule 53 (d)
Throwing Stick	Rule 71

GOAL AWARDED TO NON-OFFENDING TEAM

Open Goal with Illegal Opposing Team Interference	Rule 57(f)
Open Goal with attacking player fouled from behind	Rule 61(i)
Open Goal with attacking player tripped from behind	Rule 74(c)
Open Goal with goal cage deliberately displaced	Rule 29(h)
Opposing Player Interferes with Penalty Shot	Rule 28(i)